



# Operating instructions MESSKO® MPREC®. Pressure relief device

5789879/05 EN



© All rights reserved by Maschinenfabrik Reinhausen

Dissemination and reproduction of this document and use and disclosure of its content are strictly prohibited unless expressly permitted.

Infringements will result in liability for compensation. All rights reserved in the event of the granting of patents, utility models or designs.

The product may have been altered since this document was published.

We reserve the right to change the technical data, design and scope of supply.

Generally the information provided and agreements made when processing the individual quotations and orders are binding.

The product is delivered in accordance with MR's technical specifications, which are based on information provided by the customer. The customer has a duty of care to ensure the compatibility of the specified product with the customer's planned scope of application.

The original operating instructions were written in German.

# Table of contents

<b>1</b>	<b>Introduction .....</b>	<b>5</b>
1.1	Manufacturer .....	5
1.2	Subject to change without notice .....	5
1.3	Completeness .....	5
1.4	Safekeeping .....	6
1.5	Notation conventions .....	6
1.5.1	Hazard communication system .....	6
1.5.2	Information system .....	7
1.5.3	Instruction system .....	7
1.5.4	Typographic conventions .....	8
<b>2</b>	<b>Safety .....</b>	<b>9</b>
2.1	Intended use .....	9
2.2	Fundamental safety instructions .....	10
2.3	Personnel qualification .....	12
2.4	Personal protective equipment .....	13
<b>3</b>	<b>Product description .....</b>	<b>14</b>
3.1	Scope of delivery .....	14
3.2	Function description .....	14
3.3	Design/versions .....	15
3.3.1	Pressure relief device with standard protective cover .....	16
3.3.2	Pressure relief device with OD protective cover .....	18
3.4	Safety markings and nameplate .....	19
<b>4</b>	<b>Packaging, transport and storage .....</b>	<b>21</b>
4.1	Purpose .....	21
4.2	Suitability, structure and production .....	21
4.3	Markings .....	22
4.4	Transportation, receipt and handling of shipments .....	22
4.5	Storage of shipments .....	24
4.6	Further transport .....	24
<b>5</b>	<b>Mounting .....</b>	<b>25</b>
5.1	Mounting pressure relief device with standard protective cover .....	27
5.2	Mounting pressure relief device with OD protective cover .....	32

5.3	Electrically connecting the pressure relief device .....	39
5.3.1	Connection via cable glands .....	40
5.3.2	Connection via terminal box .....	42
5.3.3	Connection via plug (ANSI or Westinghouse).....	43
<b>6</b>	<b>Commissioning .....</b>	<b>46</b>
<b>7</b>	<b>Operation.....</b>	<b>48</b>
7.1	Pressure relief device operating state.....	48
7.2	Venting the pressure relief device.....	49
<b>8</b>	<b>Maintenance and inspection .....</b>	<b>51</b>
<b>9</b>	<b>Fault elimination .....</b>	<b>52</b>
9.1	Testing the tripping circuit and reason for tripping .....	52
<b>10</b>	<b>Disposal .....</b>	<b>53</b>
10.1	SVHC information in accordance with the REACH regulation .....	53
<b>11</b>	<b>Technical data.....</b>	<b>54</b>
<b>12</b>	<b>Drawings.....</b>	<b>59</b>
12.1	7257026.....	60
12.2	7266672.....	61
12.3	7267429 .....	64
12.4	7266974 .....	66
12.5	8235729.....	69
	<b>Glossary .....</b>	<b>72</b>

# 1 Introduction

This technical file contains detailed descriptions on the safe and proper installation, connection, commissioning and monitoring of the product.

This technical document is intended solely for specially trained and authorized personnel.

## 1.1 Manufacturer

Maschinenfabrik Reinhausen GmbH  
Falkensteinstraße 8  
93059 Regensburg  
Deutschland  
+49 941 4090-0  
[sales@reinhausen.com](mailto:sales@reinhausen.com)  
[reinhausen.com](http://reinhausen.com)

MR Reinhausen customer portal: <https://portal.reinhausen.com>.

Further information on the product and copies of this technical file are available from this address if required.

## 1.2 Subject to change without notice

The information contained in this technical file comprises the technical specifications approved at the time of printing. Significant modifications will be included in a new edition of the technical file.

The document number and version number of this technical file are shown in the footer.

## 1.3 Completeness

This technical document is incomplete without the supporting documents.

The following documents apply to this product:

- Operating instructions
- Test certificate

## 1.4 Safekeeping

Keep this technical file and all supporting documents ready at hand and accessible for future use at all times.

## 1.5 Notation conventions

This section contains an overview of the symbols and textual emphasis used.

### 1.5.1 Hazard communication system

Warnings in this technical file are displayed as follows.

#### 1.5.1.1 Warning relating to section

Warnings relating to sections refer to entire chapters or sections, sub-sections or several paragraphs within this technical document. Warnings relating to sections have the following format:

#### **▲ WARNING**



#### **Type of danger!**

Source of the danger and its consequences.

- > Action
- > Action

#### 1.5.1.2 Embedded warning information

Embedded warnings refer to a particular part within a section. These warnings apply to smaller units of information than the warnings relating to sections. Embedded warnings use the following format:

**⚠ DANGER!** Instruction for avoiding a dangerous situation.

### 1.5.1.3 Signal words

Depending on the product, the following signal words are used:

Signal word	Meaning
DANGER	Indicates a hazardous situation which, if not avoided, will result in death or serious injury.
WARNING	Indicates a hazardous situation which, if not avoided, could result in death or serious injury.
CAUTION	Indicates a hazardous situation which, if not avoided, could result in minor or moderate injury.
NOTICE	Indicates measures to be taken to prevent damage to property.

Table 1: Signal words in warning notices

## 1.5.2 Information system

Information is designed to simplify and improve understanding of particular procedures. In this technical file it is laid out as follows:

**i**

Important information.

## 1.5.3 Instruction system

This technical file contains single-step and multi-step instructions.

### Single-step instructions

Instructions which consist of only a single process step are structured as follows:

Aim of action

✓ Requirements (optional).

1. Step 1 of 1.

» Result of step (optional).

» Result of action (optional).

### Multi-step instructions

Instructions which consist of several process steps are structured as follows:

Aim of action

✓ Requirements (optional).

1. Step 1.

» Result of step (optional).

2. Step 2.

» Result of step (optional).

» Result of action (optional).

## 1.5.4 Typographic conventions

Typographic convention	Purpose	Example
UPPERCASE	Operating controls, switches	ON/OFF
[Brackets]	PC keyboard	[Ctrl] + [Alt]
<b>Bold</b>	Software operating controls	Press <b>Continue</b> button
...>...>...	Menu paths	Parameter > Control parameter
<i>Italics</i>	System messages, error messages, signals	<i>Function monitoring alarm triggered</i>
[▶ Number of pages]	Cross reference	[▶ Page 41].
<u>Dotted underscore</u> .....	Glossary entry, abbreviations, definitions, etc.	<u>Glossary entry</u> .....

Table 2: Typographic conventions used in this technical file



## 2 Safety

This technical document contains detailed descriptions on the safe and proper installation, connection, commissioning and monitoring of the product.

- Read this technical document through carefully to familiarize yourself with the product.
- This technical document is a part of the product.
- Read and observe the safety instructions provided in this chapter in particular.
- Observe the warnings in this technical document in order to avoid function-related dangers.
- The product is manufactured on the basis of state-of-the-art technology. Nevertheless, risks to life and limb of the user or impairment of the product and other material assets may occur during use due to function-related dangers.

### 2.1 Intended use

The pressure relief device protects transformers and on-load tap-changers against impermissible pressure increases. At a predetermined pressure, the pressure relief device opens, relieves the pressure and closes tightly again once the pressure has dropped.

The product is designed solely for use in stationary large-scale systems.

If used as intended and in compliance with the requirements and conditions specified in this technical file as well as the warning notices in this technical file and attached to the product, then the product does not present any danger to people, property or the environment. This applies throughout the service life of the product, from delivery, installation and operation to removal and disposal.

The following is considered intended use:

- Only use the product for the transformer type specified in the order and the associated operating data.
- You will find the standard valid for the product and the year of issue on the nameplate.
- Operate the product in accordance with this technical documentation, the agreed-upon delivery conditions and the technical data.
- Ensure that all necessary work is performed by qualified personnel only.
- Use the equipment and special tools supplied solely for the intended purpose and in accordance with the specifications of this technical file.
- Only operate the product in industrial areas. Observe the notices in this technical document regarding electromagnetic compatibility and the technical data.

## 2.2 Fundamental safety instructions

To prevent accidents, malfunctions and damage as well as unacceptable adverse effects on the environment, those responsible for transport, installation, operation, maintenance and disposal of the product or parts of the product must ensure the following:

### Personal protective equipment

Loosely worn or unsuitable clothing increases the danger of becoming trapped or caught up in rotating parts and the danger of getting caught on protruding parts. This results in danger to life and limb.

- All necessary devices and personal protective equipment required for the specific task, such as a hard hat, safety footwear, etc. must be worn. Observe the "Personal protective equipment" [► Section 2.4, Page 13] section.
- Never wear damaged personal protective equipment.
- Never wear rings, necklaces or other jewelry.
- If you have long hair, wear a hairnet.

## Work area

Untidy and poorly lit work areas can lead to accidents.

- Keep the work area clean and tidy.
- Make sure that the work area is well lit.
- Observe the applicable laws for accident prevention in the relevant country.

## Explosion protection

Highly flammable or explosive gases, vapors and dusts can cause serious explosions and fire.

- Do not install or operate the product in areas where a risk of explosion is present.

## Safety markings

Warning signs and safety information plates are safety markings on the product. They are an important aspect of the safety concept. Safety markings are depicted and described in the chapter "Product description".

- Observe all safety markings on the product.
- Make sure all safety markings on the product remain intact and legible.
- Replace safety markings that are damaged or missing.

## Ambient conditions

To ensure reliable and safe operation, the product must only be operated under the ambient conditions specified in the technical data.

- Observe the specified operating conditions and requirements for the installation location.

## Modifications and conversions

Unauthorized or inappropriate changes to the product may lead to personal injury, material damage and operational faults.

- Only modify the product after consultation with Maschinenfabrik Reinhausen GmbH.

### **Spare parts**

Spare parts not approved by Maschinenfabrik Reinhausen GmbH may lead to physical injury, damage to the product and malfunctions.

- Only use spare parts that have been approved by Maschinenfabrik Reinhausen GmbH.
- Contact Maschinenfabrik Reinhausen GmbH.

### **Working during operation**

You must only operate the product when it is in a sound operational condition. Otherwise it poses a danger to life and limb.

- Regularly check the operational reliability of safety equipment.
- Perform the inspection tasks described in this technical document regularly.

## **2.3 Personnel qualification**

The person responsible for assembly, commissioning, operation and inspection must have the following qualifications.

### **Electrically skilled person**

The electrically skilled person has a technical qualification and therefore has the required knowledge and experience, and is also conversant with the applicable standards and regulations. The electrically skilled person is also proficient in the following:

- Can identify potential dangers independently and is able to avoid them.
- Is able to perform work on electrical systems.
- Is specially trained for the working environment in which (s)he works.
- Must satisfy the requirements of the applicable statutory regulations for accident prevention.

### **Technical Service**

We strongly recommend having repairs and retrofitting carried out by our Technical Service department. This ensures that all work is performed correctly. If a repair is not carried out by our Technical Service department, please ensure that the personnel who carry out the maintenance are trained and authorized by Maschinenfabrik Reinhausen GmbH to carry out the work.

## Maschinenfabrik Reinhausen GmbH

Technical Service

Postfach 12 03 60

93025 Regensburg

Germany

+49 941 4090-0

[service@reinhausen.com](mailto:service@reinhausen.com)

[reinhausen.com](http://reinhausen.com)

## 2.4 Personal protective equipment

Personal protective equipment must be worn during work to minimize risks to health.

- Always wear the personal protective equipment required for the job at hand.
- Never wear damaged personal protective equipment.
- Observe information about personal protective equipment provided in the work area.

<b>Protective clothing</b>	Close-fitting work clothing with a low tearing strength, with tight sleeves and with no protruding parts. It mainly serves to protect the wearer against being caught by moving machine parts.
<b>Safety shoes</b>	To protect against falling heavy objects and slipping on slippery surfaces.
<b>Safety glasses</b>	To protect the eyes from flying parts and splashing liquids.
<b>Visor</b>	To protect the face from flying parts and splashing liquids or other dangerous substances.
<b>Hard hat</b>	To protect against falling and flying parts and materials.
<b>Hearing protection</b>	To protect against hearing damage.
<b>Protective gloves</b>	To protect against mechanical, thermal and electrical hazards.

Table 3: Personal protective equipment

# 3 Product description

## 3.1 Scope of delivery

The following components are included in the delivery:

- MPREC® pressure relief device
- Technical documents
- O-ring 95x3 (only for MPREC® with OD protective cover)
- Mounting seal ring (optional)
- Connecting flange for oil escape opening with internal thread or for welding (optional, and only for MPREC® with OD protective cover)
- Socket connection cable (optional, and only for MPREC® with plug connection)

Please note the following:

- Check the shipment for completeness using the shipping documents.
- Leave parts in the packaging and store in a dry area until installation.

## 3.2 Function description

The pressure relief device with the device flange is mounted tightly on the transformer tank or on the on-load tap-changer. If the internal pressure of the transformer or the on-load tap-changer exceeds the predefined operating pressure of the pressure relief device, then the spring-loaded valve plate lifts off of its seal seat within a few milliseconds. As a result, the internal pressure is relieved as quickly as possible and the valve plate again closes the pressure relief device tightly.

As an external indication that the valve has tripped, a self-locking signal pin slides out of the housing and, optionally, a semaphore straightens.

Once the pressure falls below the operating pressure, the valve closes again. The signal pin and the semaphore must be reset in their operating positions manually. The signaling contacts installed as an option are automatically reset in the process.

The pressure relief device is available in 2 versions:

- With sheet-aluminum standard protective cover
- With cast-aluminum OD protective cover (**Oil Directed** = with directed oil flow)

The construction and function are identical.

### 3.3 Design/versions

The pressure relief device consists of a device flange with valve, spring assembly, signal pin, protective cover; as an option, also with 1 or 2 micro-switches and with semaphore.

The design and the designation of the most important device components can be found in the following drawings:

- Pressure relief device with standard protective cover [[▶ Section 3.3.1, Page 16](#)]
- Pressure relief device with OD protective cover [[▶ Section 3.3.2, Page 18](#)] (English: **Oil Directed** = with directed oil flow)

The device flange of the pressure relief device is mounted tightly onto the counter flange of the transformer tank or on-load tap-changer cover via a mounting seal ring. A spring assembly presses the valve plate onto the gasket seat, which consists of one axially and one radially arranged sealing lip. The spring assembly is tensioned via 6 fixing screws between a counter bearing and the device flange.

The signal pin has a cap that can be screwed off so that the protective cover can be removed from the device flange. The signal pin comes in different colors depending on the type and suitability of the gasket materials for various insulating fluids in the transformer/on-load tap-changer:

- Red (anodized) for mineral oil
- Blue (anodized) for alternative insulating fluids (silicone oil, Pyranol and similar)

The optional micro-switches for the signaling contacts are encapsulated, structurally separated from the functional part of the valve and are therefore protected from environmental influences and escaping oil.

### 3.3.1 Pressure relief device with standard protective cover

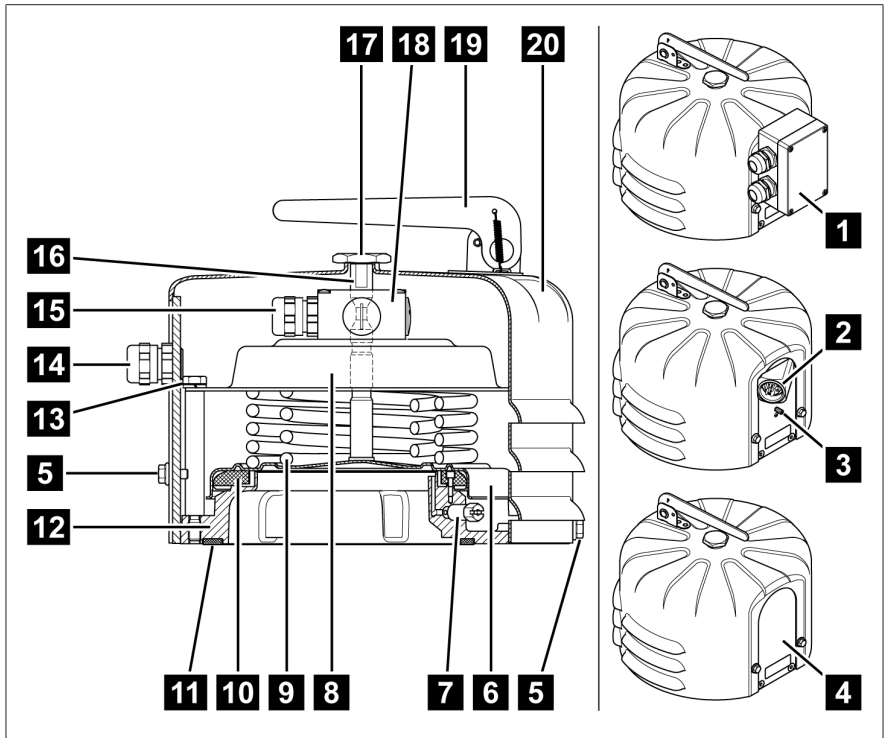

Figure 1: Pressure relief device with standard protective cover

1	Terminal box	2	ANSI plug or Westinghouse plug
3	Ground connection (only in versions with plug)	4	Without connection, without micro-switches (steel plate without drill holes)
5	3 housing screws M6x10	6	Valve plate
7	Vent screw	8	Counter bearing for spring assembly



9	Spring assembly	10	Gasket (axial) with sealing lip (radial)
11	Mounting seal ring (optional)	12	Device flange
13	6 counter bearing fixing screws	14	M20x1.5 cable gland for cable diameter 5...14 mm (optional 1/2" NPT adapter for customer-side pipe connection)
15	M20x1.5 cable gland on the micro-switch	16	Signal pin
17	Signal pin cap	18	1 or 2 micro-switches (optional)
19	Semaphore (optional)	20	Standard protective cover

### 3.3.2 Pressure relief device with OD protective cover

The OD protective cover has an escape opening to drain the oil in the event of tripping. The oil escape opening is designed as a flange for connecting a pipe to be able to drain the escaping oil selectively. An accompanying o-ring seals the flange connection.

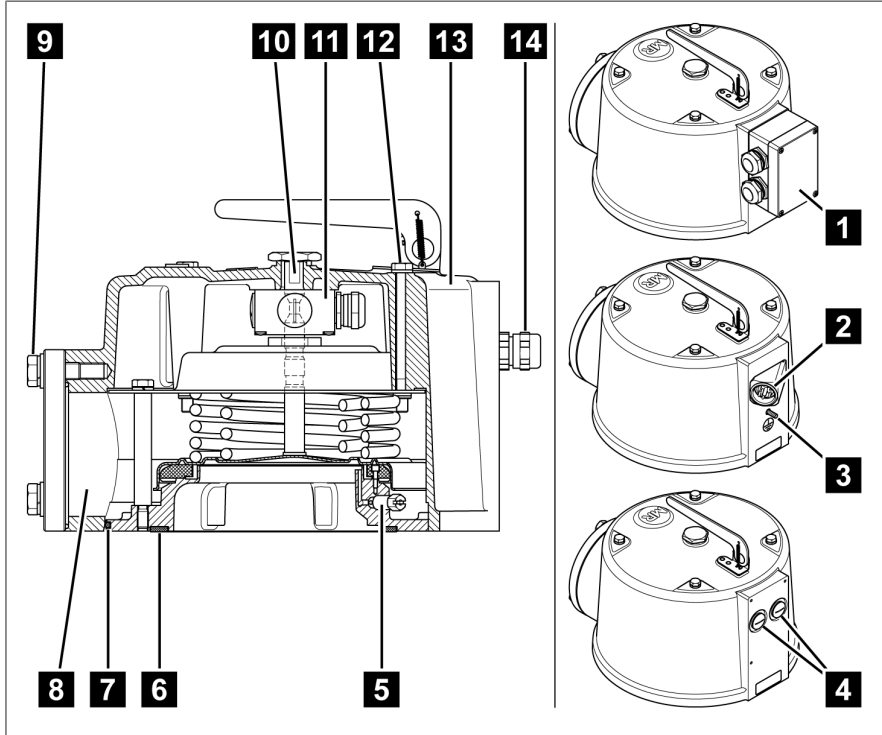

Figure 2: Pressure relief device with OD protective cover

1	Terminal box	2	ANSI plug or Westinghouse plug
3	Ground connection (only in versions with plug)	4	Without connection, without micro-switches (2 steel plates with dummy fittings)
5	Vent screw	6	Mounting seal ring (optional)
7	O-ring gasket between device and protective cover	8	Oil escape opening

9	Pipe connection with o-ring 95x3 and 3 hexagon screws M12x40 with washer and spring washer, wrench size 19	10	Signal pin with signal pin cap
11	1 or 2 micro-switches (optional)	12	4 housing screws M8x100
13	OD protective cover	14	M20x1.5 cable gland for cable diameter 5...14 mm (optional 1/2" NPT adapter for customer-side pipe connection)

### 3.4 Safety markings and nameplate

The safety marking is on the counter bearing of the spring assembly.

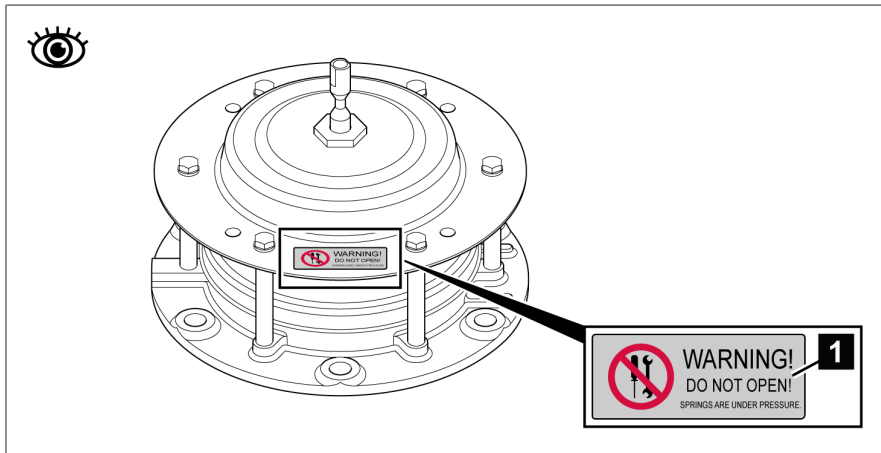



Figure 3: Safety marking

1		<p>Adhesive label on the counter bearing of the spring assembly:</p> <p>Risk of injury! Observe the notices in the operating instructions; see section Mounting [▶ Section 5, Page 25]</p>
---	---	--

The nameplate is on the stand plate for the pressure relief device with standard protective cover, and on the flat surface on the cover for the version with the OD protective cover.

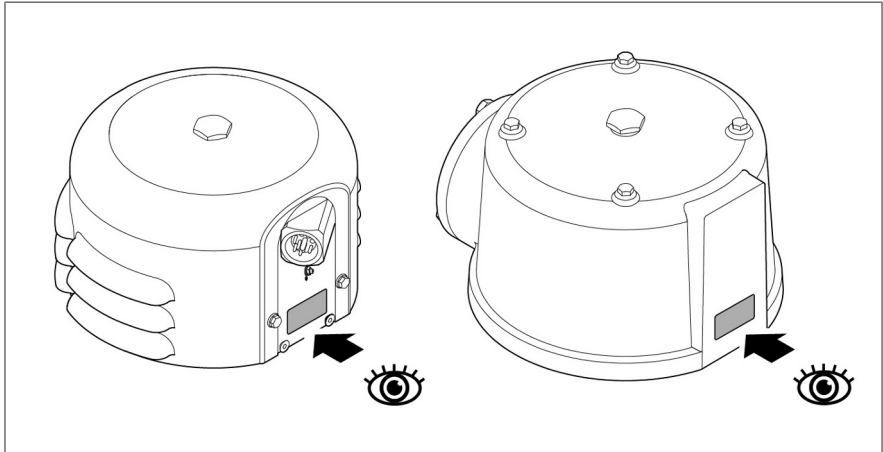

Figure 4: Nameplate on the MPREC®

## 4 Packaging, transport and storage

### 4.1 Purpose

The packaging is designed to protect the packaged product during transport, loading, unloading and during periods of storage in such a way that no detrimental changes occur. The packaging must protect the goods against permitted transport stresses such as vibration, knocks and moisture (rain, snow, condensation).

The packaging also prevents the packaged goods from moving impermissibly within the packaging.

### 4.2 Suitability, structure and production

The goods are packaged in a sturdy cardboard box or solid wooden crate. These ensure that the shipment is secure when in the intended transportation position and that none of its parts touch the loading surface of the means of transport or touch the ground after unloading.

Inlays inside the box or crate stabilize the goods, preventing impermissible changes of position and protecting them from vibration.

## 4.3 Markings

The packaging bears a signature with instructions for safe transport and correct storage. The following symbols apply to the shipment of non-hazardous goods. Adherence to these symbols is mandatory.





				
Protect against moisture	Top	Fragile	Attach lifting gear here	Center of mass

Table 4: Shipping pictograms

## 4.4 Transportation, receipt and handling of shipments

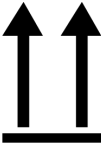
In addition to vibrations, jolts must also be expected during transportation. To prevent possible damage, avoid dropping, tipping, knocking over and colliding with the product.

If the packaging tips over or falls, damage is to be expected regardless of the weight.

Every delivered shipment must be checked for the following by the recipient before acceptance (acknowledgment of receipt):

- Completeness based on the delivery slip
- External damage of any type.

The checks must take place after unloading when the cartons or transport container can be accessed from all sides.

## Visible damage

If external transport damage is found upon receipt of the shipment, proceed as follows:

- Immediately record the transport damage found in the shipping documents and have this countersigned by the carrier.
- In the event of severe damage, total loss or high damage costs, immediately notify the sales department at Maschinenfabrik Reinhausen GmbH and the relevant insurance company.
- After identifying damage, do not modify the condition of the shipment further and retain the packaging material until an inspection decision has been made by the transport company or the insurance company.
- Record the details of the damage immediately on site together with the carrier involved. This is essential for any claim for damages.
- If possible, photograph damage to packaging and packaged goods. This also applies to signs of corrosion on the packaged goods due to moisture inside the packaging (rain, snow, condensation).
- Be absolutely sure to also check the sealed packaging.

## Hidden damage

When damage is not determined until unpacking after receipt of the shipment (hidden damage), proceed as follows:

- Make the party responsible for the damage liable as soon as possible by telephone and in writing, and prepare a damage report.
- Observe the time periods applicable to such actions in the respective country. Inquire about these in good time.

With hidden damage, it is very hard to make the transportation company (or other responsible party) liable. Any insurance claims for such damage can only be successful if relevant provisions are expressly included in the insurance terms and conditions.

## 4.5 Storage of shipments

When selecting and setting up the storage location, ensure the following:

- Store the product and accessories in the original packaging until installation.
- Protect stored goods against moisture (rain, flooding, water from melting snow and ice), dirt, pests such as rats, mice, termites etc. and against unauthorized access.
- Store crates and boxes on pallets, timber beams or planks as protection against ground moisture and for improved ventilation.
- Ensure that the foundation has sufficient load-bearing capacity.
- Keep entrance paths clear.
- Check the stored goods at regular intervals. Also take appropriate action after storms, heavy rain or snow etc.

## 4.6 Further transport

Use the original product packaging for further transport.

If you transport the product to the final installation site in a mounted state, observe the following information in order to protect the product against mechanical damage due to external influences.

### Transport packaging requirements

- Select packaging suitable for the duration of transport or storage, taking the climatic conditions into consideration.
- Ensure that the packaging protects the product against transport stress such as shaking, vibrations and impacts.
- Ensure that the packaging protects the product against moisture such as rain, snow and condensation.
- Ensure that the packaging allows for sufficient air circulation in order to prevent the formation of condensation.



# 5 Mounting

This chapter describes how to correctly mount and connect the device.

The pressure relief device is mounted on a device flange on the transformer or on-load tap-changer.

Note the connection diagrams provided.

## DANGER



### **Electric shock!**

Risk of fatal injury due to electrical voltage. Always observe the following safety regulations when working in or on electrical equipment.

- > Disconnect the equipment.
- > Lock the equipment to prevent an unintentional restart.
- > Make sure all poles are de-energized.
- > Ground and short-circuit.
- > Cover or cordon off adjacent energized parts.

## WARNING



### **Risk of injury**

Danger of serious injury due to springs that are under high tension.

- > Never unscrew the fixing screws of the counter bearing.

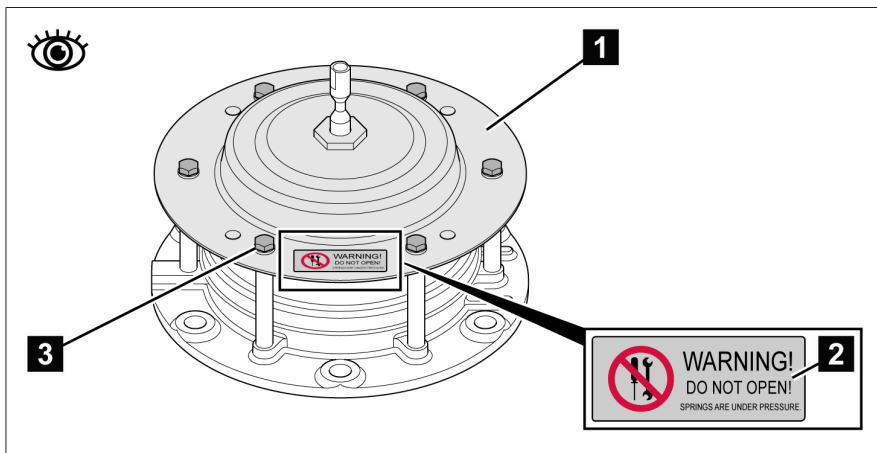

Figure 5: Safety marking: Risk of injury due to spring assembly

1	Counter bearing for spring assembly	2	Safety marking
3	6 counter bearing fixing screws		

## NOTICE

### Property damage!

The function of the device will be impaired due to drying. As a result, the transformer will no longer be protected against impermissible pressure increases.

- > Ensure that the device is not dried in the oven.
- > Only mount the device once the transformer / on-load tap-changer has been dried.

The pressure relief device can be mounted horizontally or vertically. When mounting the standard version vertically, the stand plate must face either to the left or right. When mounting the OD version, the oil escape opening must face downwards in order to ensure complete drainage of the oil in the event of tripping.

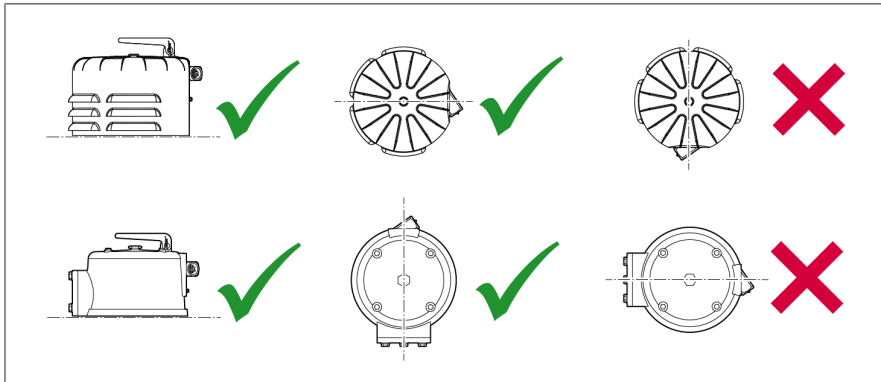

Figure 6: Possible mounting positions

There must be a clearance of at least 100 mm above or in front of the device, and at least 170 mm with a semaphore. Thus, in the Alarm position, the signal pin can be pushed fully out of the housing and the semaphore can fold out completely.

## 5.1 Mounting pressure relief device with standard protective cover

You must open the device to be able to mount it. Close the device after mounting it.

## Opening the device

1. Pull out the signal pin and screw the signal pin cap off.

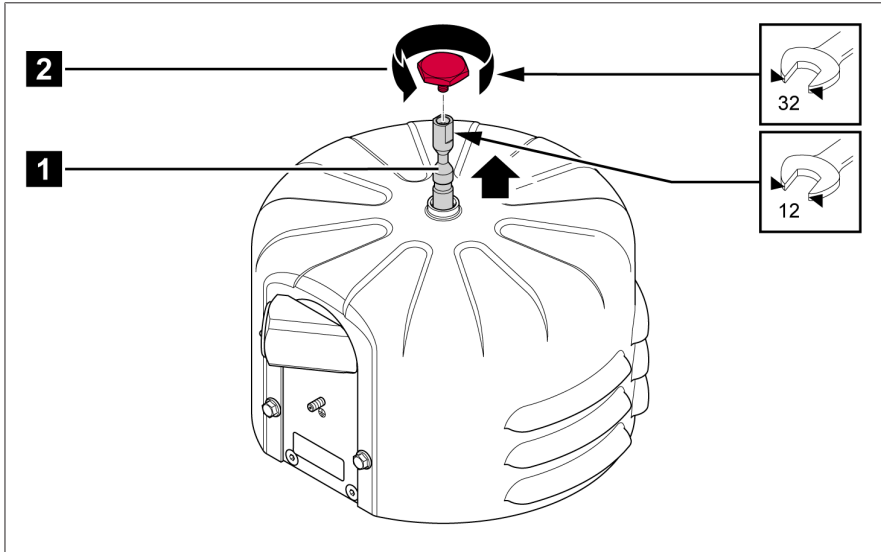

Figure 7: Pulling out the signal pin and removing the signal pin cap

1	Signal pin	2	Signal pin cap
---	------------	---	----------------

2. Unscrew and remove the 3 housing screws.

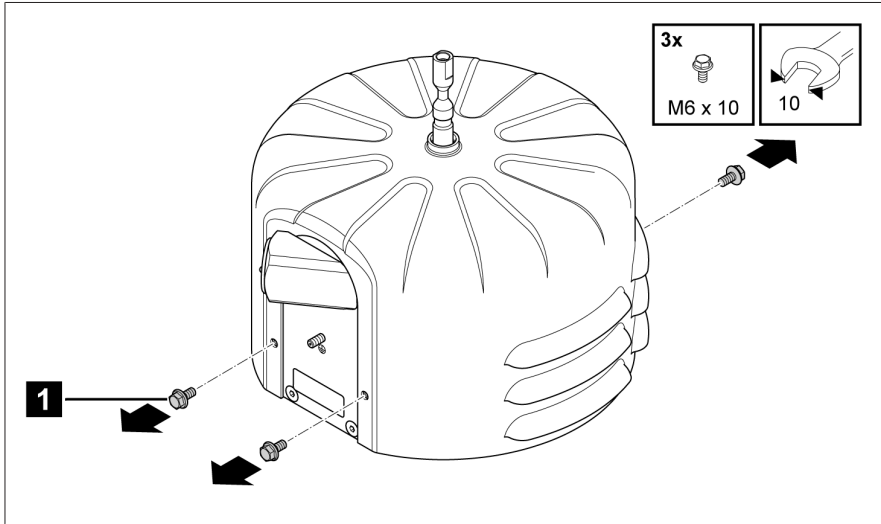

Figure 8: Unscrewing and removing the housing screws

1	3 housing screws M6x10		
---	------------------------	--	--

3. Lift off the protective cover and place it on a stable surface.

### Mounting the device

Refer to the Drawings [► Section 12, Page 59] chapter for dimensions and connection data.

1. **NOTICE!** Malfunction! To ensure that the device can function correctly, make sure that there is at least 100 mm of free space above or in front of the device when choosing the installation location. The free space has to be at least 170 mm for versions with semaphore.
2. Place the mounting seal ring (can be delivered as an option) under the device in the groove provided for this. **NOTICE!** Malfunction! An incorrectly seated mounting seal ring can result in leaks. When mounting, ensure that the assembly seal ring is seated correctly in the groove provided for this.

3. Mount the device onto the counter flange on the transformer/on-load tap-changer by inserting 6 screws (M12 or 1/2") through the drill holes in the device flange.

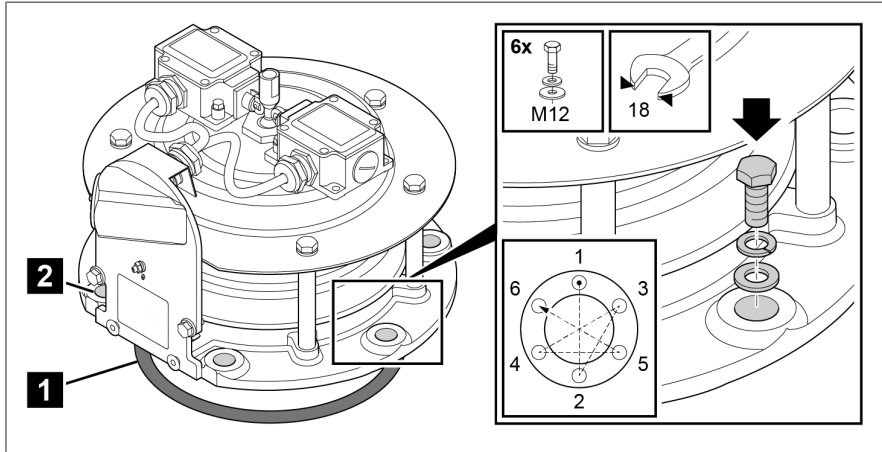

Figure 9: Mounting the device

1 Mounting seal ring	2 6 screws (M12 or 1/2")
----------------------	--------------------------

### Closing the device

1. If the device is equipped with micro-switches for remote transmission of the signals, first connect these micro-switches; see Electrically connecting the pressure relief device [► Section 5.3, Page 39].
2. Place the protective cover onto the device so that the drill holes for the 3 housing screws in the protective cover are aligned with the corresponding threaded holes in the device.

3. Affix the protective cover using the 3 housing screws.

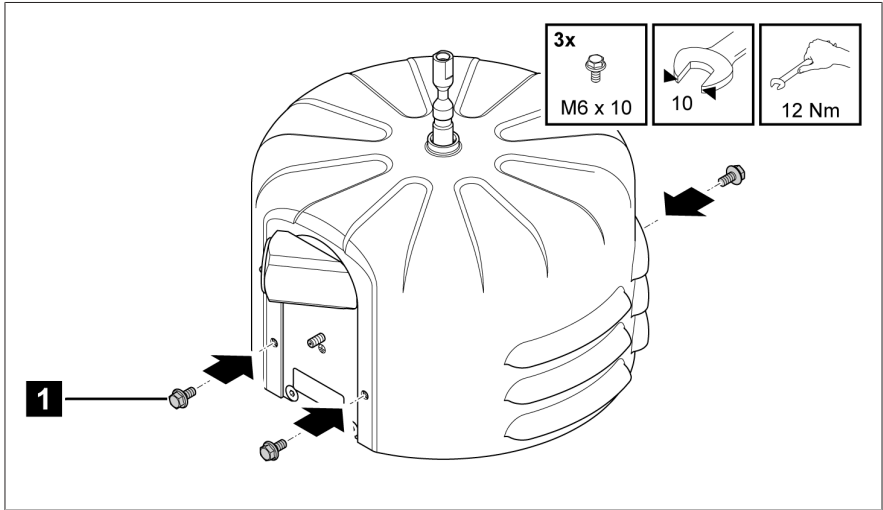

Figure 10: Affixing the protective cover

1	3 housing screws M6x10		
---	------------------------	--	--

### Establishing operational readiness

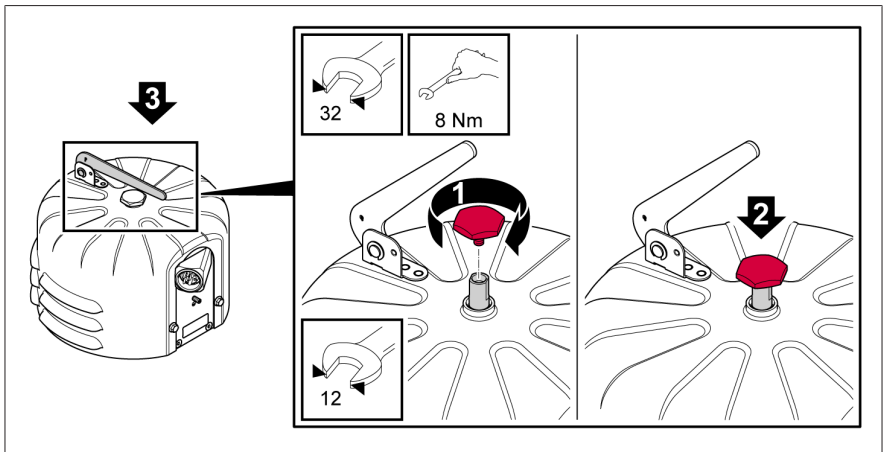

Figure 11: Establishing operational readiness

1. Screw the signal pin cap onto the signal pin.
  2. Push the signal pin into the device as far as it will go.
  3. If the device is equipped with a semaphore, fold it down so that its lower edge is perpendicular to the signal pin.
- » The pressure relief device is visibly in the operating position.

## 5.2 Mounting pressure relief device with OD protective cover

You must open the device to be able to mount it. Close the device after mounting it.

### Opening the device

1. Pull out the signal pin and screw the signal pin cap off.

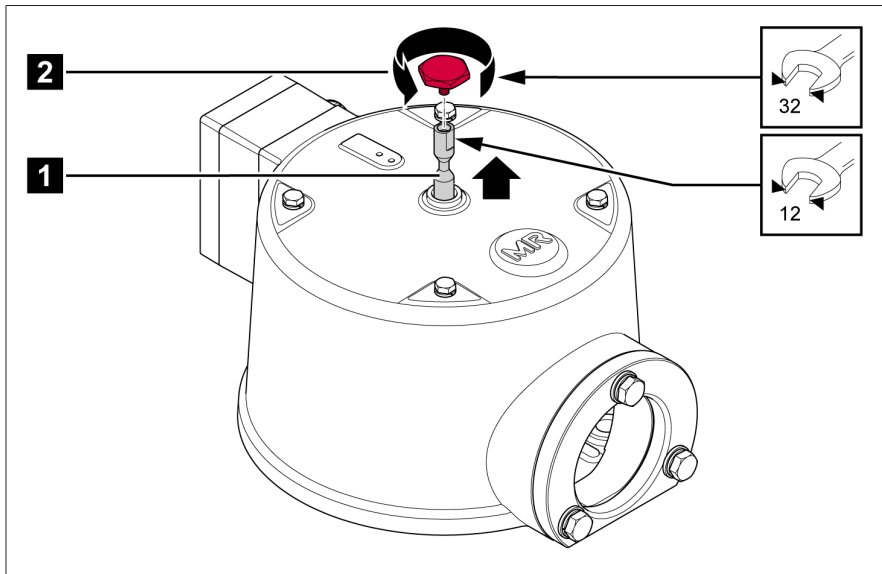

Figure 12: Pulling out the signal pin and removing the signal pin cap

1	Signal pin	2	Signal pin cap
---	------------	---	----------------



2. Unscrew and remove the 4 housing screws.

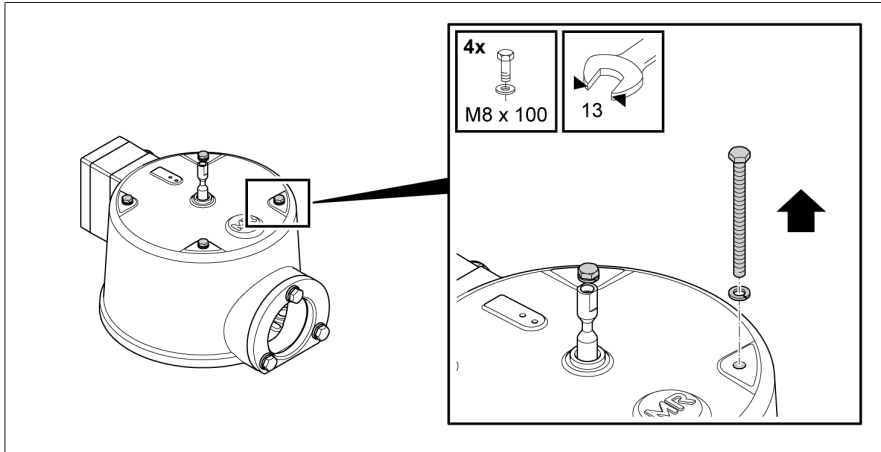

Figure 13: Unscrewing and removing the housing screws

3. Lift off the protective cover and place it on a stable surface.

### Mounting the device

Refer to the Drawings [► Section 12, Page 59] chapter for dimensions and connection data.

1. **NOTICE!** Malfunction! To ensure that the device can function correctly, make sure that there is at least 100 mm of free space above or in front of the device when choosing the installation location. The free space has to be at least 170 mm for versions with semaphore.
2. Place the mounting seal ring (can be delivered as an option) under the device in the groove provided for this. **NOTICE!** Malfunction! An incorrectly seated mounting seal ring can result in leaks. When mounting, ensure that the assembly seal ring is seated correctly in the groove provided for this.

3. Mount the device onto the counter flange on the transformer/on-load tap-changer by inserting 6 screws (M12 or 1/2") through the drill holes in the device flange.

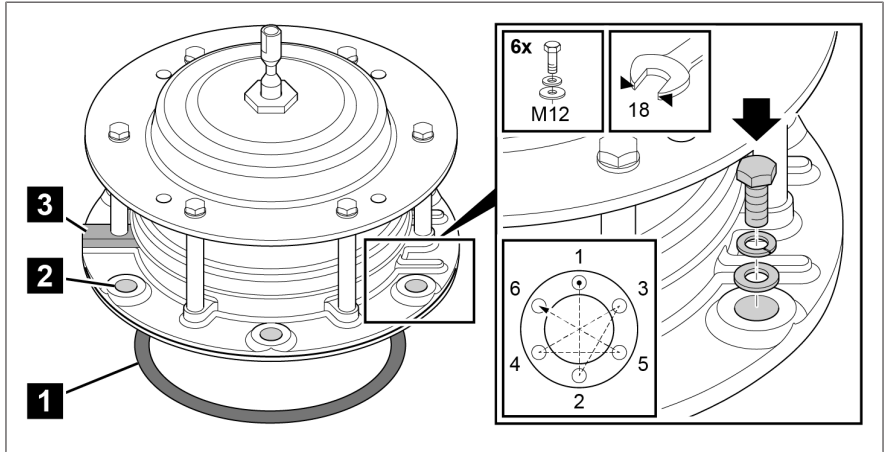

Figure 14: Mounting the device

1	Mounting seal ring	2	6 screws (M12 or 1/2")
3	Through-bar of the device flange		

## Closing the device

1. If the device is equipped with micro-switches for remote transmission of the signals, first connect these micro-switches; see Electrically connecting the pressure relief device [► Section 5.3, Page 39].
2. **NOTICE!** Damage to the o-ring gasket. Protect the o-ring gasket between the device and the protective cover and, during all intermediate steps, only position the protective cover lightly and do not press it down.

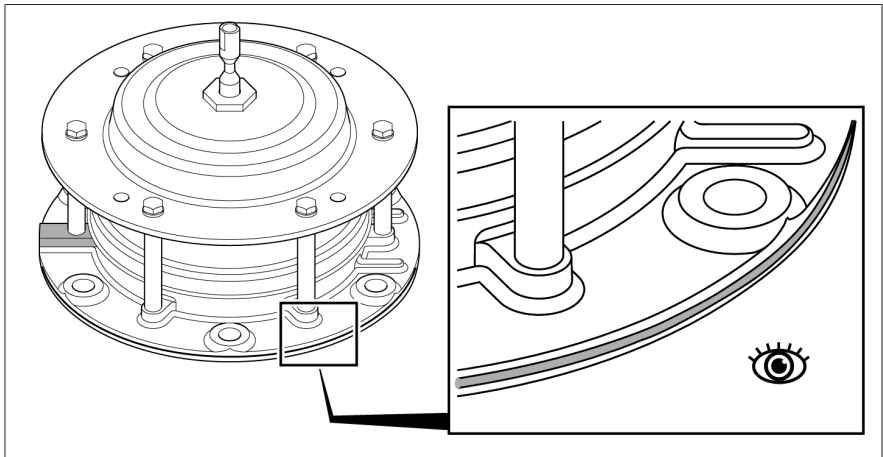

Figure 15: Protecting the o-ring gasket

3. Lower the protective cover parallel to the device flange and place it lightly on the spring assembly, without pressing the protective cover over the o-ring. When aligning the protective cover, ensure that the through-bar of the device flange is vertical under the terminal board of the protective cover. The threaded bolts of the spring assembly must be visible precisely in the center of the oil escape opening.

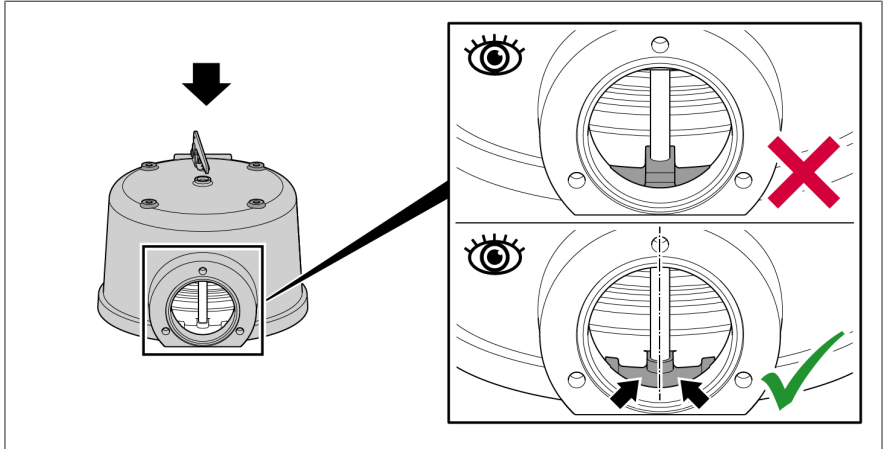

Figure 16: Aligning the OD protective cover

4. Insert the 4 housing screws into the intended holes and turn the protective cover gently around its axis until the screws engage in the threads in the counter bearing.

5. **NOTICE!** Do not tilt or jam the protective cover. Tighten the 4 screws slightly crosswise several times to prevent that the protective cover does not tilt or jam while it is being lowered.

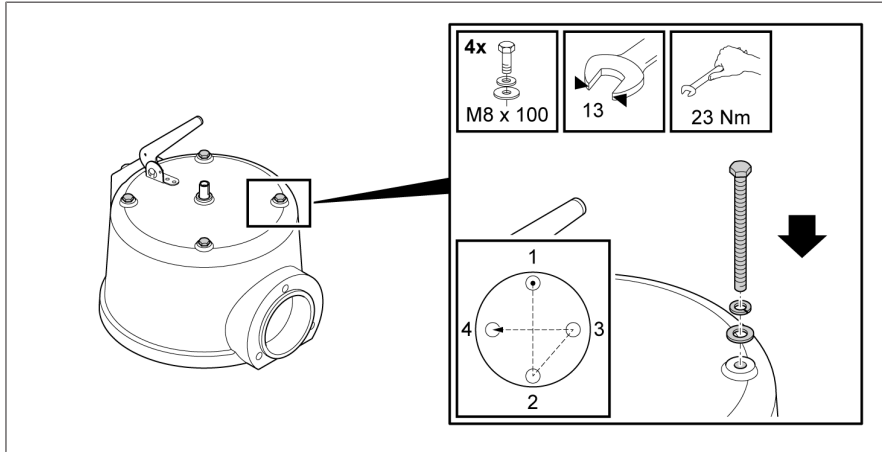

Figure 17: Positioning and closing the OD protective cover

6. Then tighten the 4 housing screws in a crosswise sequence up to a maximum torque of 23 Nm.

## NOTICE

### Malfunction of the pressure relief device!

The oil escape opening of the pressure relief device is closed with a plastic cap as protection during transport. The pressure relief device will not function with the plastic cap still in place. Therefore, please note the following:

- > After mounting the protective cover, remove the plastic cap.
- > Never use the plastic cap as a closing cap during operation.

## Mounting the oil drainage unit

The o-ring gasket and the 3 hexagon screws with spring washers and washers are included with the device. A suitable connecting flange with internal thread or for welding can be ordered as an option.

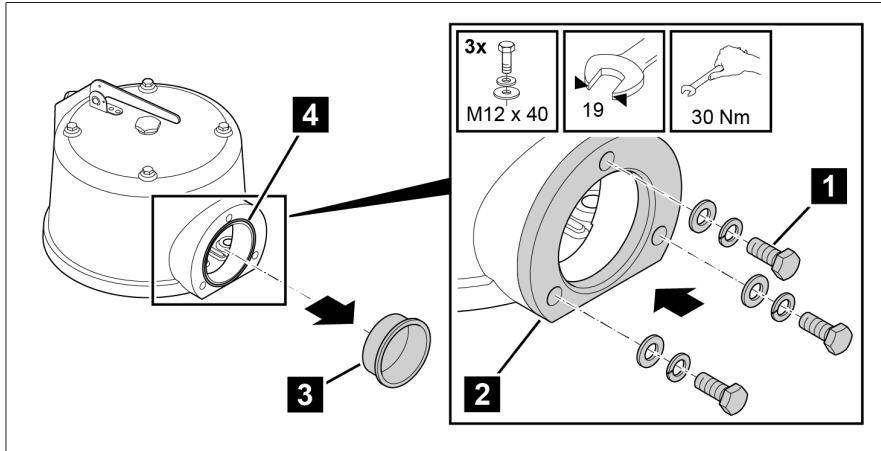

Figure 18: Mounting the oil drainage unit

1	3 hexagon screws M12x40 with spring washers and washers (included)	2	Counter flange of the drainage unit
3	Plastic cap as transport lock	4	O-ring 95x3 (included)

1. Flange-mount a drainage unit onto the oil escape opening.
2. **NOTICE!** The dimensions of the connecting flanges and a recommendation on the design of the drainage pipe can be found in the attached diagram "MPREC Ableitrohr/DRAINAGE PIPE", material number 101716100M sheet 1 to 3.

## Establishing operational readiness

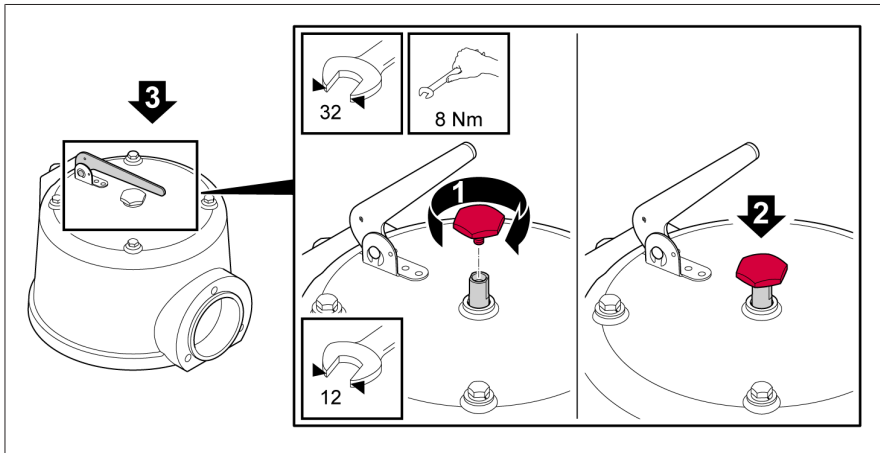

Figure 19: Establishing operational readiness

1. Screw the signal pin cap onto the signal pin.
2. Push the signal pin into the device as far as it will go.
3. If the device is equipped with a semaphore, fold it down so that its lower edge is perpendicular to the signal pin.
  - » The pressure relief device is visibly in the operating position.

## 5.3 Electrically connecting the pressure relief device

### ⚠ WARNING



#### Danger of death or severe injury!

Danger of death or severe injury due to improper electrical connection of the pressure relief device.

- > When the pressure relief device trips, the transformer must be immediately de-energized by the circuit breaker.
- > Ensure that the pressure relief device's signaling contact is correctly looped into the tripping circuit of the transformer circuit breaker.

### Connecting the micro-switches (optional)

Depending on the version, the micro-switches can be connected by one of the following methods:

- Cable glands
- Terminal box
- ANSI plug or Westinghouse plug

Each micro-switch is designed as an electrically isolated NO and NC contact.

#### 5.3.1 Connection via cable glands

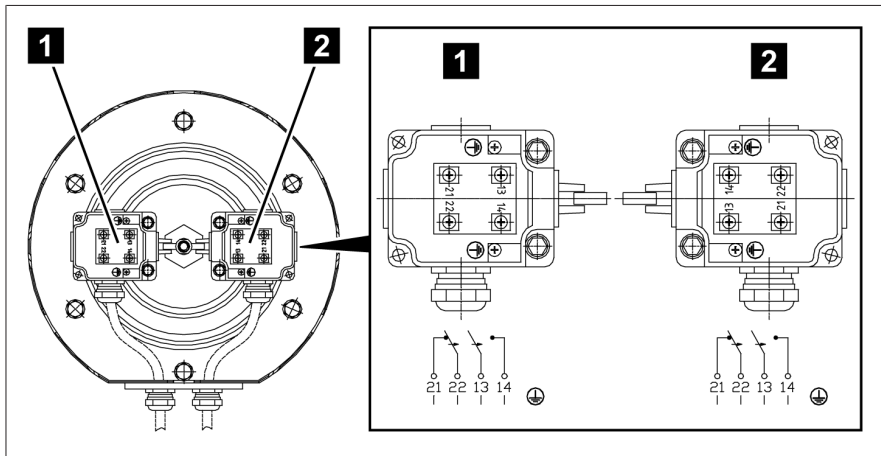

Figure 20: Connecting the micro-switches in the pressure relief device with standard protective cover

1	Micro-switch 1	2	Micro-switch 2 (if not installed, the outer cable gland is replaced with a dummy plug)
---	----------------	---	--



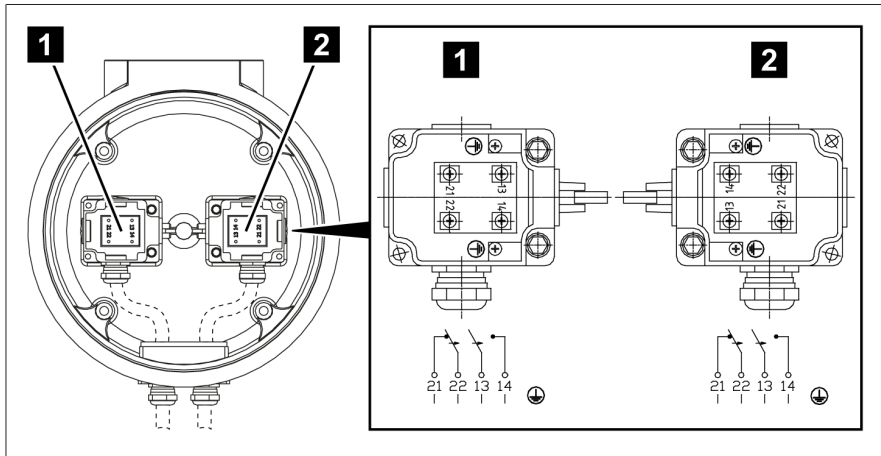

Figure 21: Connecting the micro-switches in the pressure relief device with OD protective cover

1 Micro-switch 1	2 Micro-switch 2 (if not installed, the outer cable gland is replaced with a dummy plug)
------------------	--

1. Open the device: In versions with standard protective cover [► Section 5.1, Page 27], the micro-switches are located on the counter bearing of the spring assembly. In versions with OD protective cover [► Section 5.2, Page 32], the micro-switches are located on the inside of the protective cover. Therefore, in this case lay the OD protective cover on a stable surface with the opening facing upwards for connecting the cables.
2. Remove the 4 cover bolts on the micro-switch housing and remove the cover (crosshead screwdriver).
3. Remove an amount of sheathing from the double-insulated cable (cable diameter 5...14 mm) appropriate for the wiring, strip off 7 mm of insulation from the individual wires and cap off with ferrules.
4. Open the M20x1.5 cable glands (spanner wrench, wrench size 24) on the outer cable bushing and on the micro-switch housing.
5. Pull the cable ends loosely through the outer and inner cable glands.
6. **NOTICE!** Do not kink the wires! Connect the signal lines and protective conductor to the 4 clamping screws in loose arcs in accordance with the connection diagram.

7. First tighten the inner cable gland hand-tight, and then the outer cable gland, and ensure that the cables and wires remain loose and without tension and that they are not twisted.
8. Close all cable glands (spanner wrench, wrench size 24, 5 Nm).
9. Place the cover onto the micro-switch housing and affix using the 4 cover bolts (crosshead screwdriver, 2 Nm).
10. Put on the protective cover and affix: standard protective cover [▶ Section 5.1, Page 27] or OD protective cover [▶ Section 5.2, Page 32].

### 5.3.2 Connection via terminal box

1. Unscrew the 4 screws on the terminal box (crosshead screwdriver) and remove the cover.
2. Remove an amount of sheathing from the double-insulated cable (cable diameter 11...20 mm) appropriate for the wiring, strip off 7 mm of insulation from the individual wires and cap off with ferrules.
3. Open the M25x1.5 cable gland (spanner wrench, wrench size 32) and pull the cable through.

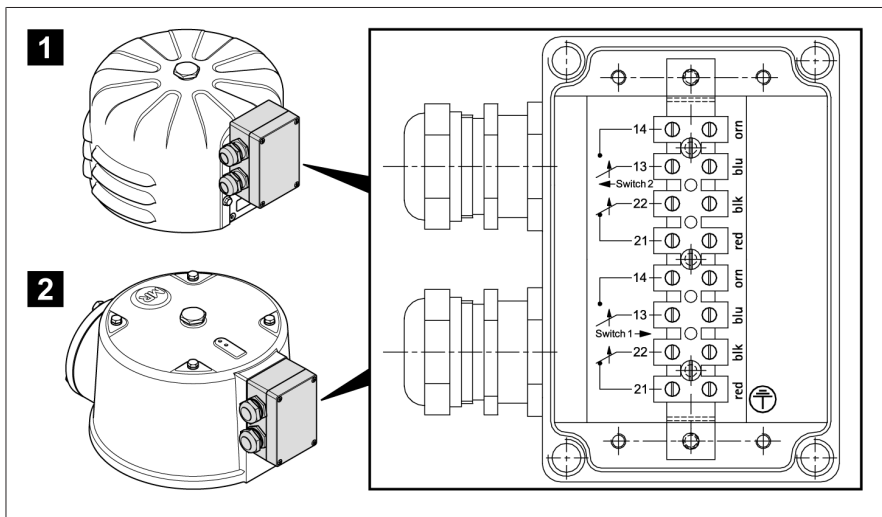

Figure 22: Connection diagram for terminal box

1	Standard protective cover	2	OD protective cover
---	---------------------------	---	---------------------

4. **NOTICE!** Do not kink the wires! Connect the signal lines and protective conductor to the labeled terminal strip in loose arcs in accordance with the connection diagram.
5. Close the cable gland (spanner wrench, wrench size 32, 6.7 Nm).
6. If used, proceed in the same way for the second cable gland.
7. If only one of the two available cable glands is used, replace the second cable gland with a dummy plug to ensure the IP degree of protection.
8. Position the cover on the terminal box and affix using the 4 screws (crosshead screwdriver,  $0.9 \text{ Nm} \pm 0.1 \text{ Nm}$ ).

### 5.3.3 Connection via plug (ANSI or Westinghouse)

Prior to connecting the device, check that the socket connection cable fits onto the plug on the device. Then proceed as follows:

1. Connect the protective conductor between the grounding screw (wrench size 10, 5 Nm) below the plug connection and the housing of the transformer or on-load tap-changer.
2. Remove the sheathing of the free end of the socket connection cable, strip off approximately 7 mm of insulation from the wires and cap off with ferrules.

3. Lay the socket connection cable between the device and switch cabinet and connect the wires in accordance with the pin assignment in the switch cabinet.

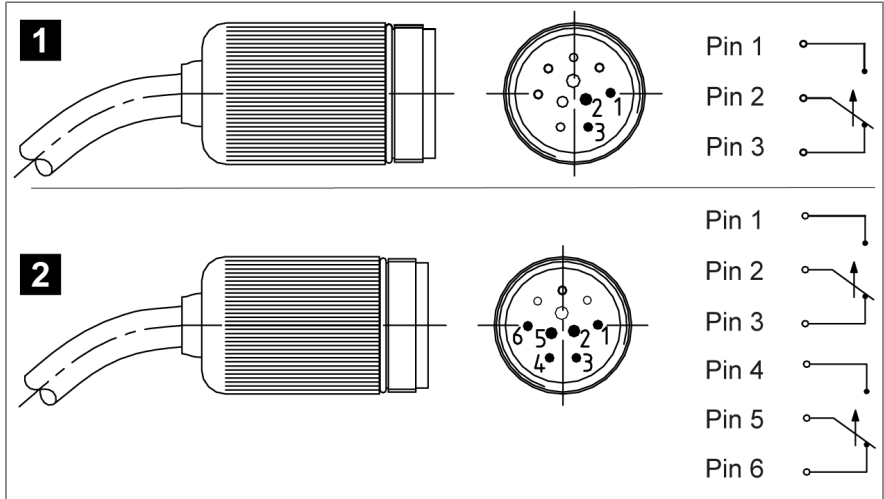

Figure 23: Plan view of the ANSI socket connection cable pin assignment

		Wire colors of the supplied cable	
1	1 micro-switch	Pin 1: Black Pin 2: Red Pin 3: Blue	-
2	2 micro-switches	Pin 1: Black Pin 2: Red Pin 3: Blue	Pin 4: Orange Pin 5: Yellow Pin 6: Brown

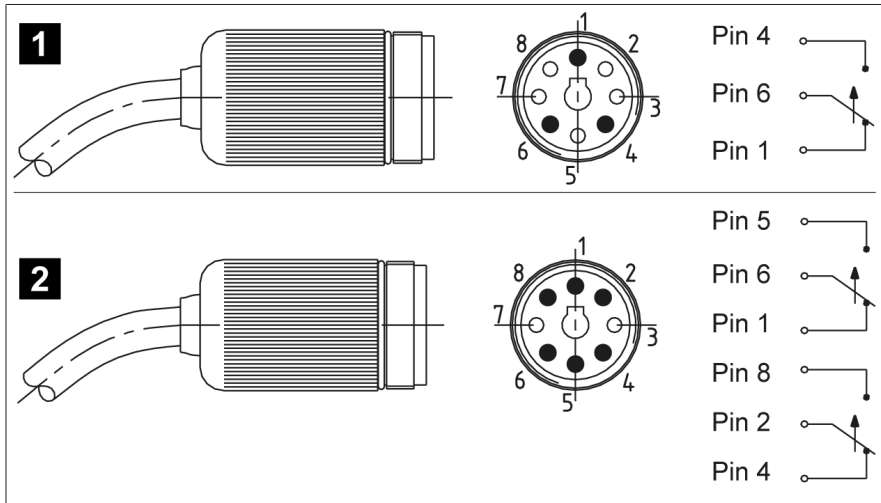

Figure 24: Plan view of the Westinghouse socket connection cable pin assignment

		Wire colors of the supplied cable	
1	1 micro-switch	Pin 1: Black Pin 4: Green Pin 6: White	-
2	2 micro-switches	Pin 1: Red Pin 5: Blue Pin 6: Orange	Pin 2: White Pin 4: Black Pin 8: Green

4. Plug the connection cable socket onto the plug.
5. Hold onto the connection cable and screw the socket housing clockwise as far as it will go. When doing so, do not allow the connection cable to turn.

## 6 Commissioning

Check that the pressure relief device is functioning correctly before commissioning the transformer/on-load tap-changer. You will find a description of the function test in the following.

As an example, the following illustrates the case where one micro-switch in the pressure relief device is wired to the tripping circuit of the circuit breaker, which de-energizes the transformer in the event of a fault.

If you have connected the micro-switches with another device, check the reaction at this device when the switching position is changed (steps 4, 7, and 9).

### ⚠ DANGER



#### Electric shock!

Risk of fatal injury due to electrical voltage. Always observe the following safety regulations when working in or on electrical equipment.

- > Disconnect the equipment.
  - > Lock the equipment to prevent an unintentional restart.
  - > Make sure all poles are de-energized.
  - > Ground and short-circuit.
  - > Cover or cordon off adjacent energized parts.
1. **⚠ WARNING!** If the micro-switches also trip the fire extinguishing unit in the event of a fault, deactivate the fire extinguishing unit prior to the function test. Otherwise, an unintentional activation of the fire extinguishing unit can cause death through suffocation. Check the signal transmission in accordance with the operating instructions for the fire extinguishing unit or contact the manufacturer.
  2. Pull the signal pin out of the housing into the Alarm position to activate the micro-switches, see the Operating status [▶ Section 7.1, Page 48] chapter.
  3. Leave the transformer's danger zone.
  4. Ensure that the transformer's circuit breaker cannot be closed.
    - » Passive protection test

5. Push the signal pin of the pressure relief device into the housing to return the micro-switches to the Operation position.
6. Leave the transformer's danger zone.
7. Close the transformer circuit breaker with the disconnecting switches open and the transformer grounded on all sides.
8. Pull the signal pin out of the housing into the Alarm position to activate the micro-switches.
9. Check whether the circuit breaker for the transformer has tripped.
  - » Active protection test.
10. Push the signal pin of the pressure relief device back to the Operation position.
11. If the fire extinguishing unit was deactivated before the test, reactivate it in accordance with the associated operating instructions of the manufacturer.
  - » After this function test, you can continue commissioning the transformer/on-load tap-changer.

# 7 Operation

## 7.1 Pressure relief device operating state

The operating state of the pressure relief device is shown from the outside by the position of the signal pin and by the position of the semaphore (optional):

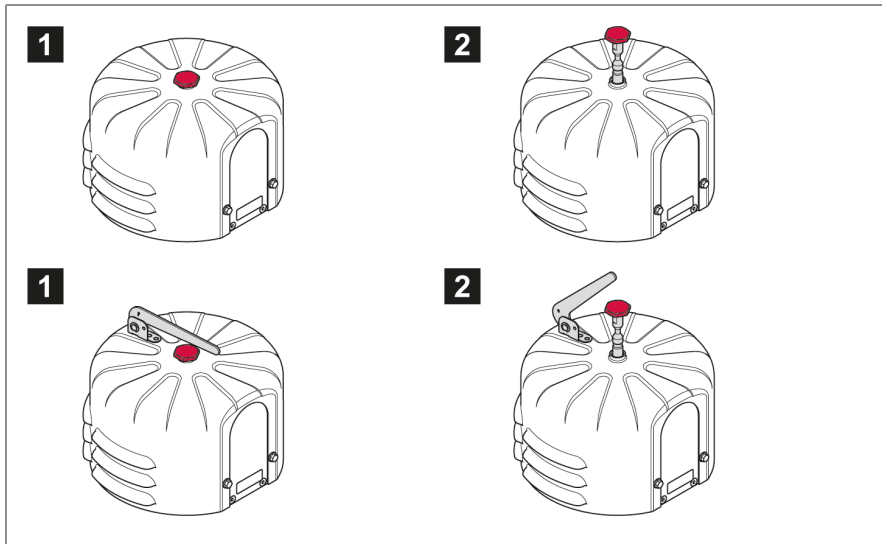

Figure 25: Operating positions of the signal pin and the semaphore (optional)

1 Operation	2 Alarm – Pressure relief device has tripped
-------------	--

If the pressure relief device has tripped, the signal pin remains in the Alarm position, even after the pressure in the transformer/on-load tap-changer has normalized again. If the micro-switches inside the housing are connected, a signal is transmitted to the control room at the same time.

- After eliminating the cause, press the signal pin (and the semaphore if present) back down manually.



If the signal pin is in the Operation position, the pressure relief device has not tripped mechanically. If a micro-switch has nonetheless issued a signal, the fault may lie in the tripping circuit, see chapter Checking the tripping circuit and tripping reason [► Section 9.1, Page 52].

## 7.2 Venting the pressure relief device

With vertical mounting, no gas accumulates under the valve plate. Venting is therefore not necessary.

With horizontal mounting, it is only necessary to vent the pressure relief device if this is recommended by the manufacturer of the transformer/on-load tap-changer.

### ▲ WARNING



#### **Danger of explosion!**

Explosive gases in the pressure relief device, in the transformer or under the on-load tap-changer head cover can blow out or explode and thus lead to death or serious injury.

- Ensure that there are no ignition sources such as naked flames, hot surfaces or sparks (e.g. caused by the build-up of static charge) in the immediate surroundings and that none occur.
- De-energize all auxiliary circuits (e.g tap-change supervisory device, pressure relief device, pressure monitoring device) before opening the pressure relief device.
- Do not operate any electrical devices during the work (e.g. risk of sparks from impact wrench).

To vent the pressure relief device after filling the transformer/on-load tap-changer, proceed as follows:

1. Consult the transformer/on-load tap-changer operating instructions and only vent the pressure relief device if the manufacturer of the transformer/on-load tap-changer recommends it.
2. Remove the protective cover from the pressure relief device, see Opening the device with standard protective cover [► Section 5.1, Page 27] or with OD protective cover [► Section 5.2, Page 32].

- Carefully unscrew the vent screw by a few turns using a wrench (wrench size 10) or a screwdriver without unscrewing it completely.

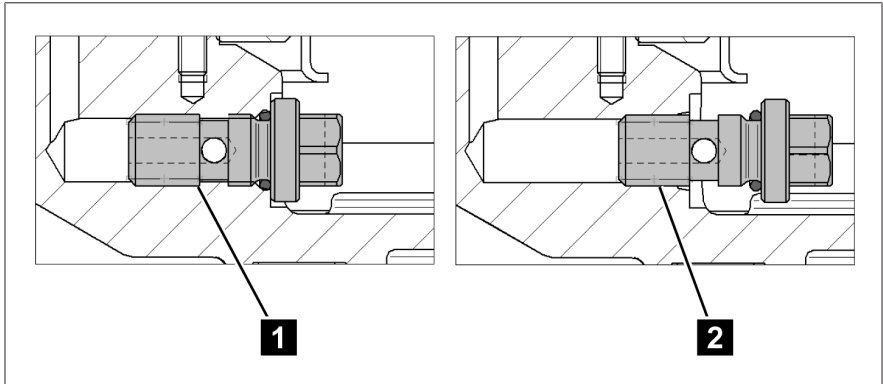

Figure 26: Vent screw positions

1	Vent screw tightened	2	Vent screw loosened
---	----------------------	---	---------------------

- As soon as oil begins to escape, tighten the screw with a maximum torque of 15 Nm.
- Close the device, see with standard protective cover [▶ Section 5.1, Page 27] or with OD protective cover [▶ Section 5.2, Page 32].
  - » The pressure relief device is ready for operation.

# 8 Maintenance and inspection

## Maintenance

The product is maintenance-free.

## Inspection

Depending on the conditions of use of the device and the national regulations in the respective country of use, the transformer manufacturers can specify different inspection intervals.

- Observe the inspection intervals defined in CIGRE Publication No. 445 "Guide for Transformer Maintenance" or the inspection intervals specified by the transformer manufacturer.

The following checks are necessary for each transformer inspection:

- Visual inspection for leaks, corrosion and damage
- Function test, see Commissioning [▶ Section 6, Page 46]

In addition, the following checks are necessary during every second transformer inspection:

- Visual inspection for leaks, corrosion and damage under the cover. To do so, remove the cover, see [▶ Section 5.1, Page 27]. (With OD protective cover only: First remove the oil escape opening pipe connection, see [▶ Section 5.2, Page 32].)
- Visual inspection of the compression springs
- Visual inspection of the flange
- Visual inspection of the switches

In the event of questions or irregularities, contact the Technical Service department:

## Maschinenfabrik Reinhausen GmbH

MR Service & Complaint

Falkensteinstraße 8

93059 Regensburg, Germany

E-Mail: [service@reinhausen.com](mailto:service@reinhausen.com) or [complaint@reinhausen.com](mailto:complaint@reinhausen.com)

# 9 Fault elimination

This chapter describes how to eliminate simple operating faults.

## 9.1 Testing the tripping circuit and reason for tripping

If the signal pin is in the Operation position, this means that the pressure relief device has not tripped. If a micro-switch has nonetheless issued a signal, the fault may lie in the tripping circuit. If this is the case, check whether the signals in the tripping circuit are transmitted reliably.

If the signal pin is in the Alarm position, this means that the pressure relief device has tripped. If this is the case, clarify the following questions and, if necessary, contact the manufacturer of the transformer/on-load tap-changer so that further measures can be taken:

- Has oil leaked from the pressure relief device?
  - Was the transformer exposed to mechanical stress?
  - What was the load of the transformer at the instant of tripping?
  - Was the on-load tap-changer in operation immediately before or during tripping?
  - Were other protective devices activated at the time of tripping?
  - Were switching operations in the network being carried out at the time of tripping?
  - Were overvoltages registered at the time of tripping?
  - How high is the static pressure on the pressure relief device (difference in height between the oil level in the conservator and in the pressure relief device)?
- Only once all potential errors have been eliminated should you push the signal pin back into the device, otherwise the valve cannot be tripped again.

# 10 Disposal

Observe the national disposal regulations in the country of use.

## 10.1 SVHC information in accordance with the REACH regulation

This product complies with the provisions of European Regulation 1907/2006/EC dated December 18, 2006 on the Registration, Evaluation, Authorization and Restriction of Chemicals (REACH).

The following components of the product contain > 0.1% [w/w] of the SVHC substance lead (CAS no. 7439-92-1):

- Aluminum alloy
- Brass alloy
- Standard parts with a low property class

# 11 Technical data

Operating conditions	
Location of use	Indoors and outdoors; tropic-proof
Ambient air temperature	-50 °C...+80 °C (mechanical version only) -40 °C...+80 °C (version with micro-switches)
Operating temperature	-40 °C...+80 °C
Insulating fluid temperature	-30 °C...+120 °C
Storage temperature	-50 °C...+80 °C
Degree of protection (terminal box, cable glands, micro-switches)	IP66 in accordance with IEC 60529
Contamination level	3
Overvoltage category	III; external protection: Miniature circuit breaker maximum 16 A, C-characteristic

Materials	
All parts	Weather-resistant and transformer oil-resistant; all external parts UV-resistant
	Offshore version: All external parts also seawater resistant
Device flange	Seawater-proof aluminum casting
Standard protective cover	Seawater-proof aluminum with powder coating RAL 7033 or RAL 7038
OD protective cover	Seawater-proof aluminum casting with powder coating RAL 7033 or RAL 7038; sealing lip in the valve plate included in the scope of delivery
	Offshore version available as an option: <ul style="list-style-type: none"> <li>- Screws in V4A in accordance with DIN 931/933</li> <li>- Cable glands in accordance with EN 60423, ISO 965</li> <li>- Paint category CX in accordance with ISO 12944</li> </ul>
Valve plate	Stainless steel

Materials	
Gasket materials	<ul style="list-style-type: none"> <li>– NBR for mineral oil</li> <li>– Viton for alternative insulating fluids (silicone oil, Pyranol and similar)</li> </ul>
Springs	Spring steel in accordance with EN 10270-1 SH, compression springs with configuration-specific parts painting (in German: KTL) for identification and corrosion protection
Signal pin	Seawater-proof aluminum; anodized
	<ul style="list-style-type: none"> <li>– Red for standard sealing lip, NBR (mineral oil)</li> <li>– Blue for Viton (alternative insulating fluids such as silicone oil, Pyranol and similar)</li> </ul>
Mounting seal ring (optional)	<ul style="list-style-type: none"> <li>– Order No.: 50032703 for NBR (mineral oil)</li> <li>– Order No.: 73314900 for Viton (alternative insulating fluids such as silicone oil, Pyranol and similar)</li> </ul>
Vent screw	Self-securing; stainless steel; wrench size 10
Semaphore	Optional; corrosion-resistant steel with powder coating RAL 1026, luminous yellow; (not suitable for offshore applications)

Dimensions	
Fastening	Ø 235 mm [Ø 9.25"] bolt circle of the 6 holes Ø 15.5 mm [Ø 0.61"]
Protective cover	Ø 265 mm [Ø 10.43"] standard protective cover
	Ø 290 mm [Ø 11.42"] OD protective cover
Oil escape opening	<p>Only for version with OD protective cover:</p> <ul style="list-style-type: none"> <li>– Ø 90 mm [3.54"] with o-ring 95x3; bolt circle of the 3 holes Ø 120 mm [Ø 4.72"]</li> <li>– Connecting flange (available as an option) with internal thread G3 1/4" or for welding</li> </ul>

Dimensions	
Height (in tripped state)	Max. 234.5 mm [9.23"] standard protective cover without semaphore Max. 340 mm [13.39"] standard protective cover with semaphore
	Max. 246 mm [9.96"] OD protective cover without semaphore Max. 342 mm [13.46"] OD protective cover with semaphore
Mounting seal ring	Available as an option; Ø 200 mm x Ø 178.5 mm x 4.25 mm [Ø 7.87" x Ø 7.03" x 0.17"]
Connection cable length for plug version	1,219 mm [48"]; 1,829 mm [72"]; 2,134 mm [84"]; 2,438 mm [96"]; 3,658 mm [144"]; 4,572 mm [180"]; 5,004 mm [197"]; 5,080 mm [200"]; 6,096 mm [240"]; 7,620 mm [300"]; 9,144 mm [360"]; 10,000 mm [394"]; 11,990 mm [472"]; 15,010 mm [591"]; 20,110 mm [792"]
Weight	Approximately 6 kg with standard protective cover Approximately 11 kg with OD protective cover

LMPRD <sup>1)</sup> type	Operating pressure		
	[psi]	[bar]	[kPa]
4-psi LMPRD	4 ± 1	0.28 ± 0.07	28 ± 6.9
5-psi LMPRD	5 ± 1	0.34 ± 0.07	34 ± 6.9
6-psi LMPRD	6 ± 1	0.41 ± 0.07	41 ± 6.9
8-psi LMPRD	8 ± 1	0.55 ± 0.07	55 ± 6.9
10-psi LMPRD	10 ± 1	0.69 ± 0.07	69 ± 6.9
12-psi LMPRD	12 ± 1	0.83 ± 0.07	83 ± 6.9
15-psi LMPRD	15 ± 2	1.03 ± 0.14	103 ± 13.8
20-psi LMPRD	20 ± 2	1.38 ± 0.14	138 ± 13.8
25-psi LMPRD	25 ± 2	1.72 ± 0.14	172 ± 13.8
30-psi LMPRD	30 ± 2	2.07 ± 0.14	207 ± 13.8
<sup>1)</sup> LMPRD = Large MESSKO® Pressure Relief Device			



Micro-switches			
Switch type	Switch with standard contacts (silver alloy), switch with gold-plated contacts		
Contact type	Standard contacts:	1 x NO (normally open contact) and 1 x NC (normally closed contact) or 2 x NO (normally open contact)	
	Gold-plated con- tacts:	1 x NO (normally open contact) and 1 x NC (normally closed contact)	
Housing material	Seawater-proof aluminum		
Rated operating voltage	$U_e = 240 \text{ V}$		
Standard contact switch- ing capacity in accordance with IEC 60076-22-1	Max. current	10 A	30 ms
		24 V DC...220 V DC	
	Making capacity	130 W	L/R <40 ms
	Breaking capacity	25 W	L/R <40 ms
		230 V AC	
	Making capacity	250 VA	$\cos \varphi > 0.5$
	Breaking capacity	60 VA	$\cos \varphi > 0.5$
Switching capacity, switch with gold-plated contacts <sup>2)</sup>		24 V DC	
	Making capacity	Max. 0.1 W	Resistive load
	Breaking capacity	Max. 0.1 W	Resistive load
Switch characteristics in accordance with IEC 60076-22-1	Minimum dielectric strength, short-term power supply frequency withstand voltage	2 kV, 1 min, between circuit and ground 1 kV, 1 min, between the contacts in the open posi- tion	
	Minimum dielectric strength lightning impulse withstand voltage	4 kV (peak), between circuit and ground 3 kV (peak), between the contacts in the open posi- tion	

Connection via cable glands	
Connection terminals	Single-wire: 0.5...2.5 mm <sup>2</sup> , AWG 21...14; wires with ferrule: 0.5...1.5 mm <sup>2</sup> , AWG 21...16
Cable glands	IP66 and offshore applications: M20x1.5 for cable diameters 5...14 mm; connection cable not included in delivery
Optional 1/2" NPT adapter	For customer-side pipe connection
Degree of protection	IP66 in accordance with IEC 60529 for enclosed devices

Connection via terminal box	
Connection terminals	Single-wire: 1...4 mm <sup>2</sup> , AWG 18...12; wires with ferrule: 0.5...2.5 mm <sup>2</sup> , AWG 21...14
Cable glands	IP66: M25x1.5 for cable diameters 11...20 mm
	Offshore version: M25x1.5 for cable diameters 11...20 mm, stainless steel
Degree of protection	IP66 in accordance with IEC 60529 for enclosed devices

Connection via plug	
Connecting cable	ANSI socket connection cable AWG 16, or Westinghouse socket connection cable AWG 16
Degree of protection	IP65 in accordance with IEC 60529 for enclosed devices

## 12 Drawings

The product may have been altered since this document was published.

© MASCHINENFABRIK REINHAUSEN GMBH, 2020  
 THE REPRODUCTION, DISTRIBUTION AND UTILIZATION OF THIS DOCUMENT AS WELL AS THE COMMUNICATION OF ITS CONTENTS TO OTHERS WITHOUT EXPRESS AUTHORIZATION IS PROHIBITED. OFFENDERS WILL BE HELD LIABLE FOR THE PAYMENT OF DAMAGES. ALL RIGHTS RESERVED IN THE EVENT OF THE GRANT OF A PATENT, UTILITY MODEL OR DESIGN.

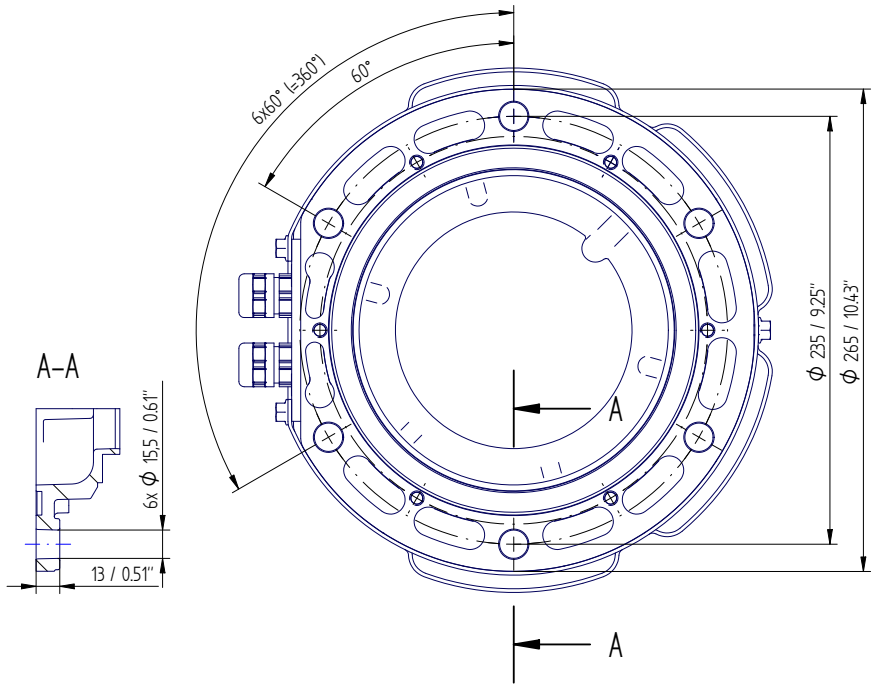

A-A

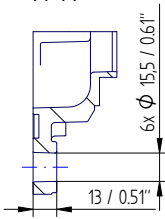

Alarmstellung /  
ALARM POSITION

Betriebsstellung /  
OPERATION POSITION

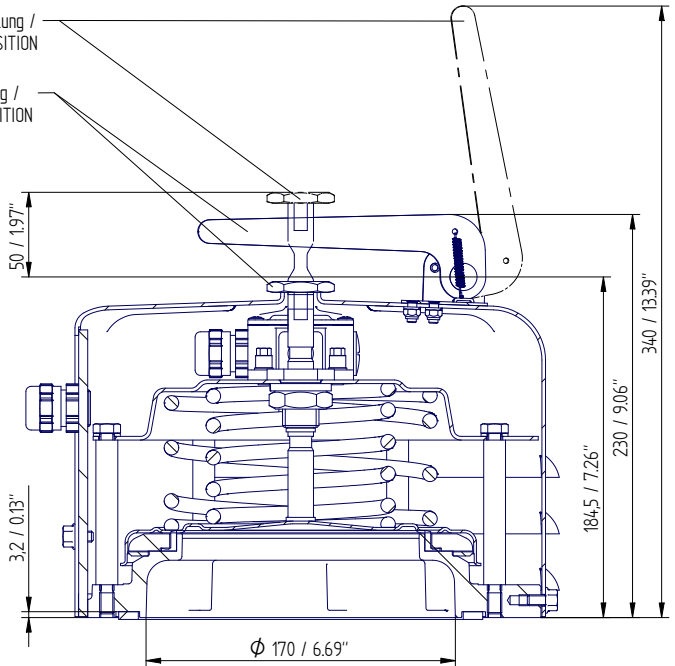

DATE	NAME	DOCUMENT NO.
-	-	SED 7257026 000 00
CHG.	SCALE	CHANGE NO.
-	-	1099741
STAND.	SCALE	CHANGE NO.
-	1:2	-

DIMENSION  
IN mm  
EXCEPT AS  
NOTED



TRANSFORMER ACCESSORIES  
 PRESSURE RELIEF DEVICE MPREC  
 STANDARD COVER

SERIAL NUMBER

MATERIAL NUMBER

SHEET  
1 / 1

© MASCHINENFABRIK REINHAUSEN GMBH 2020  
 THE REPRODUCTION, DISTRIBUTION AND UTILIZATION OF THIS DOCUMENT AS WELL AS THE COMMUNICATION OF ITS CONTENTS TO OTHERS WITHOUT EXPRESS AUTHORIZATION IS PROHIBITED. OFFENDERS WILL BE HELD LIABLE FOR THE PAYMENT OF DAMAGES. ALL RIGHTS RESERVED IN THE EVENT OF THE GRANT OF A PATENT, UTILITY MODEL OR DESIGN.

DATE	NAME	DOCUMENT NO.
DFTR 02.08.2023	THELEK	SED 7266672 000 03
CHKD 02.08.2023	SCHAEFERB	CHANGE NO.
STAND 02.08.2023	KLEYN	1123935
		SCALE
		1:2

DIMENSION  
 IN mm  
 EXCEPT AS  
 NOTED



TRANSFORMER ACCESSORIES  
 PRESSURE RELIEF DEVICE MPREC  
 STANDARD COVER - DIRECT / BOX

SERIAL NUMBER

MATERIAL NUMBER  
 101591100M

SHEET  
 1 / 3

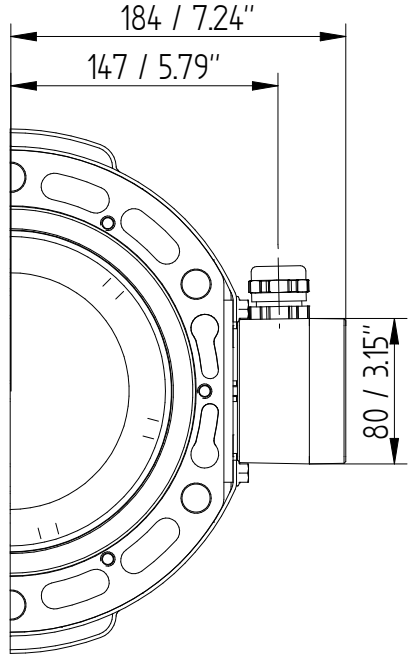
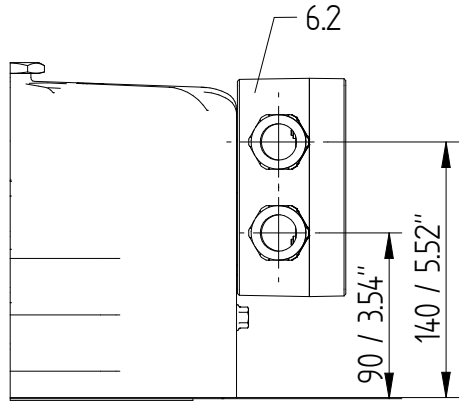
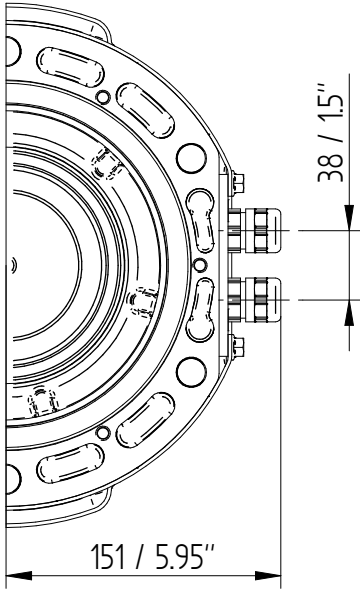
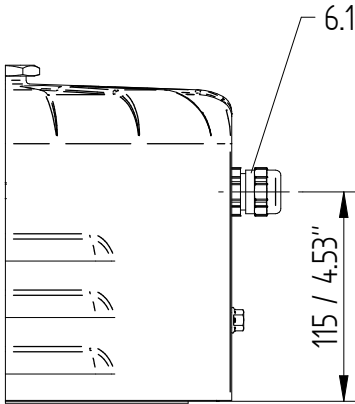

© MASCHINENFABRIK REINHAUSEN GMBH 2020  
 THE REPRODUCTION, DISTRIBUTION AND UTILIZATION OF THIS DOCUMENT AS WELL AS THE COMMUNICATION OF ITS CONTENTS TO OTHERS WITHOUT EXPRESS AUTHORIZATION IS PROHIBITED. OFFENDERS WILL BE HELD LIABLE FOR THE PAYMENT OF DAMAGES. ALL RIGHTS RESERVED IN THE EVENT OF THE GRANT OF A PATENT, UTILITY MODEL OR DESIGN.

DATE	NAME	DOCUMENT NO.
DFTR 02.08.2023	THELEK	SED 7266672 000 03
CHKD 02.08.2023	SCHAEFERB	CHANGE NO.
STAND 02.08.2023	KLEYN	1123935
		SCALE
		1:2

DIMENSION  
 IN mm  
 EXCEPT AS  
 NOTED



TRANSFORMER ACCESSORIES  
 PRESSURE RELIEF DEVICE MPREC  
 STANDARD COVER - ANSI / WESTINGHOUSE

SERIAL NUMBER

-

MATERIAL NUMBER

101591100M

SHEET

2 / 3

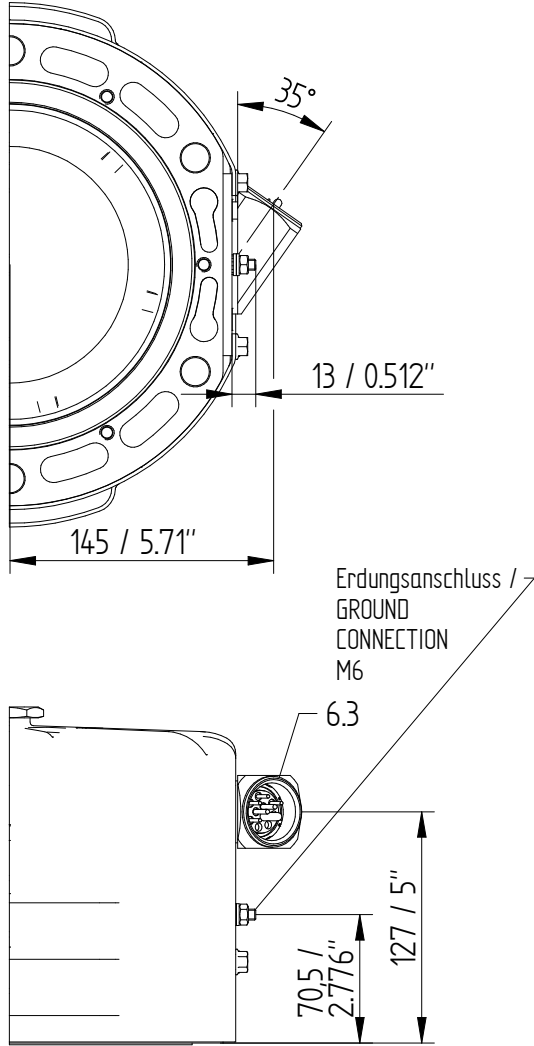

© MASCHINENFABRIK REINHAUSEN GMBH 2020  
 THE REPRODUCTION, DISTRIBUTION AND UTILIZATION OF THIS DOCUMENT AS WELL AS THE COMMUNICATION OF ITS CONTENTS TO OTHERS WITHOUT EXPRESS AUTHORIZATION IS PROHIBITED. OFFENDERS WILL BE HELD LIABLE FOR THE PAYMENT OF DAMAGES. ALL RIGHTS RESERVED IN THE EVENT OF THE GRANT OF A PATENT, UTILITY MODEL OR DESIGN.

DATE	NAME	DOCUMENT NO.
02.08.2023	THELEK	SED 7266672 000 03
02.08.2023	SCHAEFERB	CHANGE NO.
02.08.2023	KLEYN	1129935
SCALE		1:2

DIMENSION  
 IN mm  
 EXCEPT AS  
 NOTED



TRANSFORMER ACCESSORIES  
 PRESSURE RELIEF DEVICE MPREC  
 STANDARD COVER - 1/2" NPT - ADAPTER

SERIAL NUMBER

-

MATERIAL NUMBER  
 101591100M

SHEET  
 3 / 3

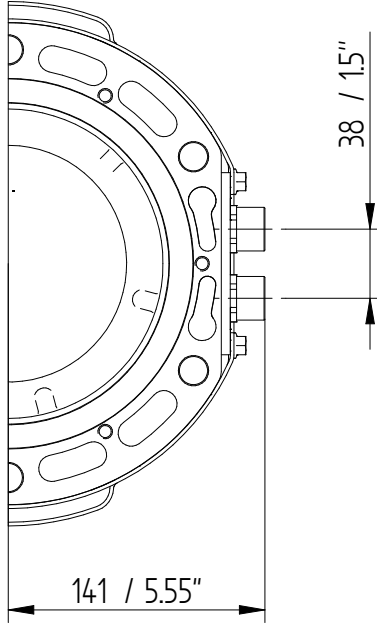
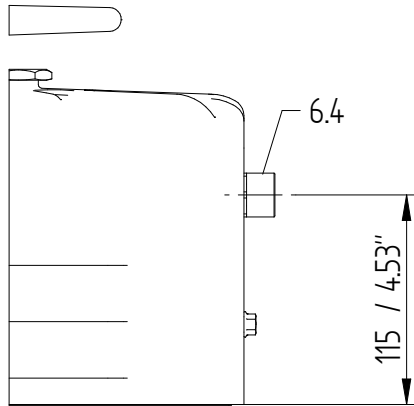

© MASCHINENFABRIK REINHAUSEN GMBH 2020  
 THE REPRODUCTION, DISTRIBUTION AND UTILIZATION OF THIS DOCUMENT AS WELL AS THE COMMUNICATION OF ITS CONTENTS TO OTHERS WITHOUT EXPRESS AUTHORIZATION IS PROHIBITED. OFFENDERS WILL BE HELD LIABLE FOR THE PAYMENT OF DAMAGES. ALL RIGHTS RESERVED IN THE EVENT OF THE GRANT OF A PATENT, UTILITY MODEL OR DESIGN.

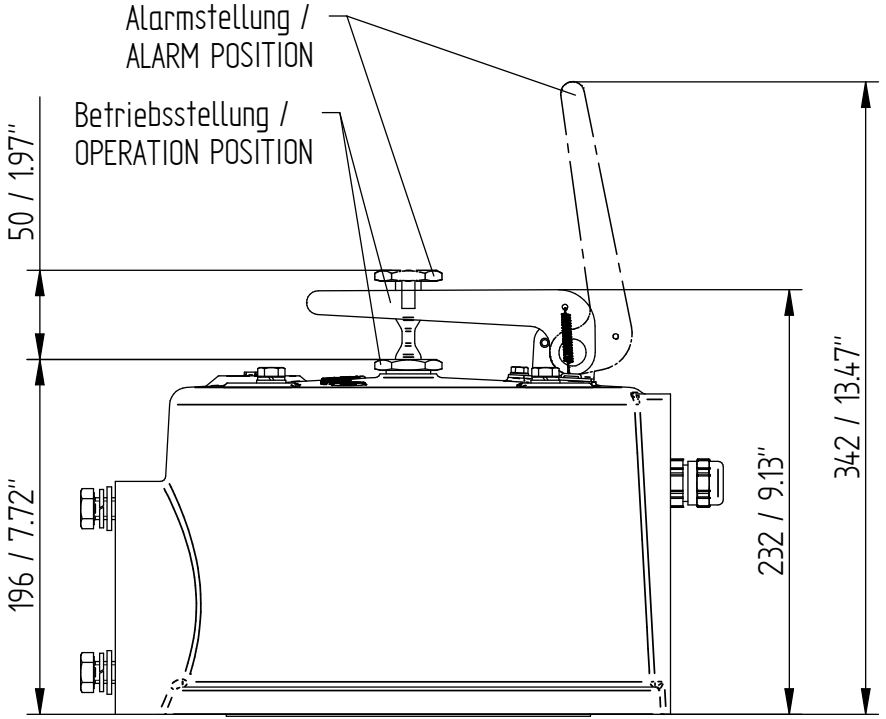

DATE	NAME	DOCUMENT NO.
DFTR_31.07.2023	THIELEK	SED 7267429 000 01
TKND_01.08.2023	SCHAEFERB	CHANGE NO.
STAND_02.08.2023	KLEYN	1123935
		SCALE
		1:2

DIMENSION  
 IN mm  
 EXCEPT AS  
 NOTED



TRANSFORMER ACCESSORIES  
 PRESSURE RELIEF DEVICE MPREC  
 OD (OIL DIRECTED) COVER

SERIAL NUMBER

-

MATERIAL NUMBER

101784200M

SHEET

1/2



© MASCHINENFABRIK REINHAUSEN GMBH, 2020  
 THE REPRODUCTION, DISTRIBUTION AND UTILIZATION OF THIS DOCUMENT AS WELL AS THE COMMUNICATION OF ITS CONTENTS TO OTHERS WITHOUT EXPRESS AUTHORIZATION IS  
 PROHIBITED. OFFENDERS WILL BE HELD LIABLE FOR THE PAYMENT OF DAMAGES. ALL RIGHTS RESERVED IN THE EVENT OF THE GRANT OF A PATENT, UTILITY MODEL OR DESIGN.

DATE	NAME	DOCUMENT NO.
01.10.2023	THIELEK	SED 7267429 000 01
01.08.2023	SCHAEFERB	CHANGE NO.
02.08.2023	KLEYN	1123935
		SCALE
		1:2

DIMENSION  
 IN mm  
 EXCEPT AS  
 NOTED



TRANSFORMER ACCESSORIES  
 PRESSURE RELIEF DEVICE MPREC  
 OD (OIL DIRECTED) COVER

SERIAL NUMBER	
-	
MATERIAL NUMBER	SHEET
101784-200M	2 / 2

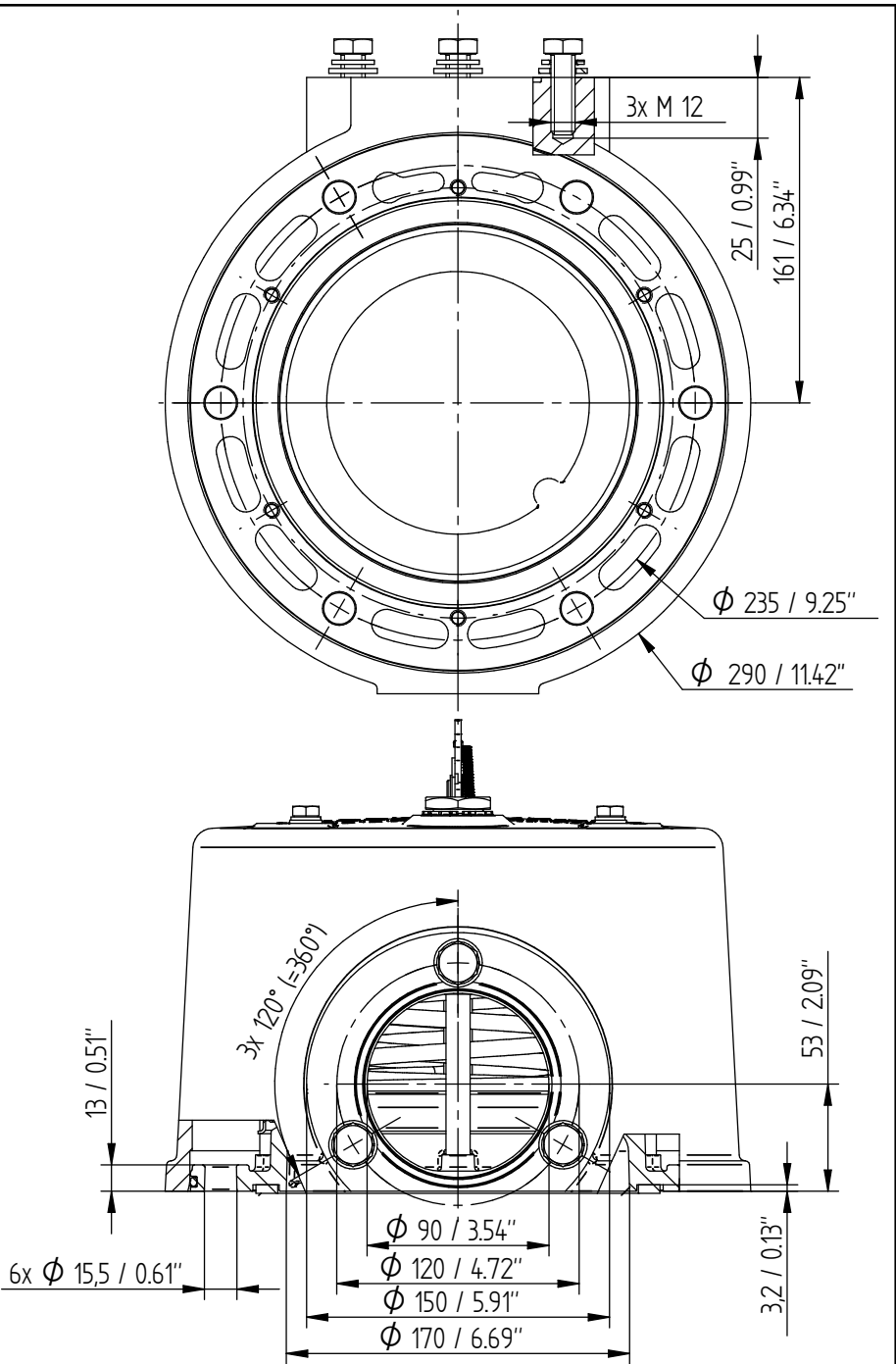

© MASCHINENFABRIK REINHAUSEN GMBH 2020  
 THE REPRODUCTION, DISTRIBUTION AND UTILIZATION OF THIS DOCUMENT AS WELL AS THE COMMUNICATION OF ITS CONTENTS TO OTHERS WITHOUT EXPRESS AUTHORIZATION IS PROHIBITED. OFFENDERS WILL BE HELD LIABLE FOR THE PAYMENT OF DAMAGES. ALL RIGHTS RESERVED IN THE EVENT OF A PATENT, UTILITY MODEL OR DESIGN.

DATE	NAME	DOCUMENT NO.
02.08.2023	THIELEK	SED 7266974-000 03
02.08.2023	SCHAEFFERB	CHANGE NO.
02.08.2023	KLEYN	1123935
		SCALE
		1:2

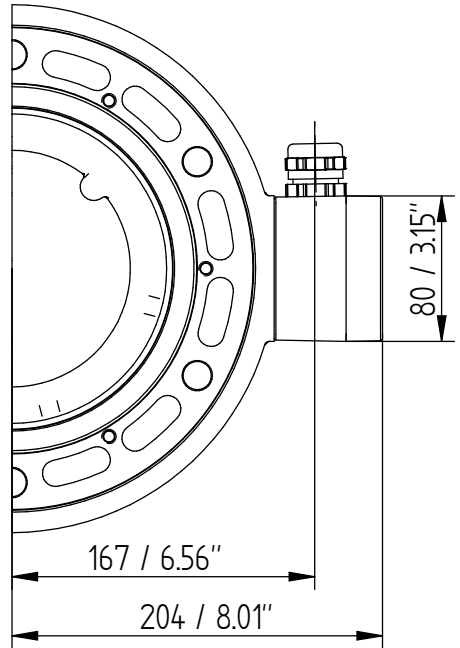
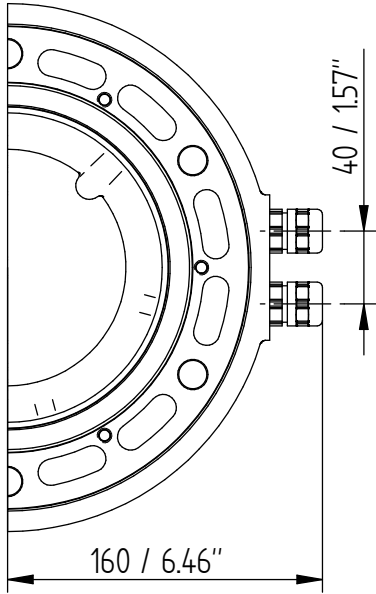
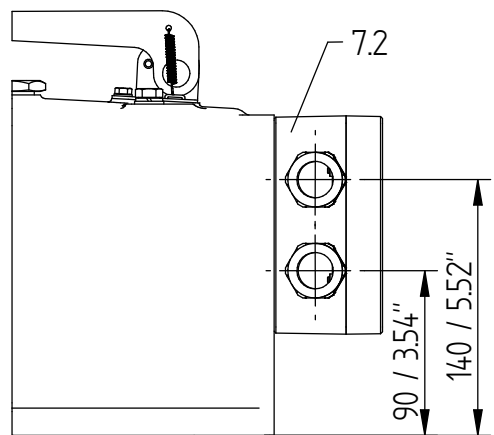
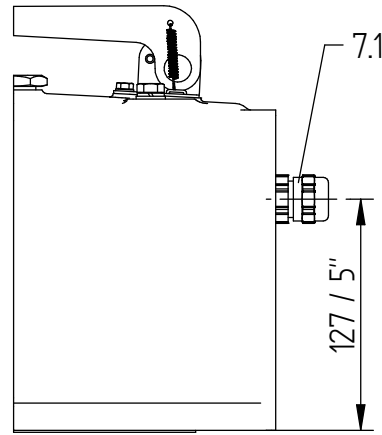

DIMENSION  
 IN mm  
 EXCEPT AS  
 NOTED



TRANSFORMER ACCESSORIES  
 PRESSURE RELIEF DEVICE MPREC  
 OD (OIL DIRECTED) COVER - DIRECT / BOX

SERIAL NUMBER	-
MATERIAL NUMBER	101591110M
SHEET	1 / 3

© MASCHINENFABRIK REINHAUSEN GMBH 2020  
 THE REPRODUCTION, DISTRIBUTION AND UTILIZATION OF THIS DOCUMENT AS WELL AS THE COMMUNICATION OF ITS CONTENTS TO OTHERS WITHOUT EXPRESS AUTHORIZATION IS PROHIBITED. OFFENDERS WILL BE HELD LIABLE FOR THE PAYMENT OF DAMAGES. ALL RIGHTS RESERVED IN THE EVENT OF THE GRANT OF A PATENT, UTILITY MODEL OR DESIGN.

DATE	NAME	DOCUMENT NO.
02.08.2023	THIELEK	SED 7266974-000 03
02.08.2023	SCHAEFERB	CHANGE NO.
02.08.2023	KLEYN	1123935
		SCALE
		1:2

DIMENSION  
 IN mm  
 EXCEPT AS  
 NOTED



TRANSFORMER ACCESSORIES  
 PRESSURE RELIEF DEVICE MPREC  
 OD (OIL DIRECTED) COVER - ANSI / WESTINGHOUSE

SERIAL NUMBER	-
MATERIAL NUMBER	10159110M
SHEET	2 / 3

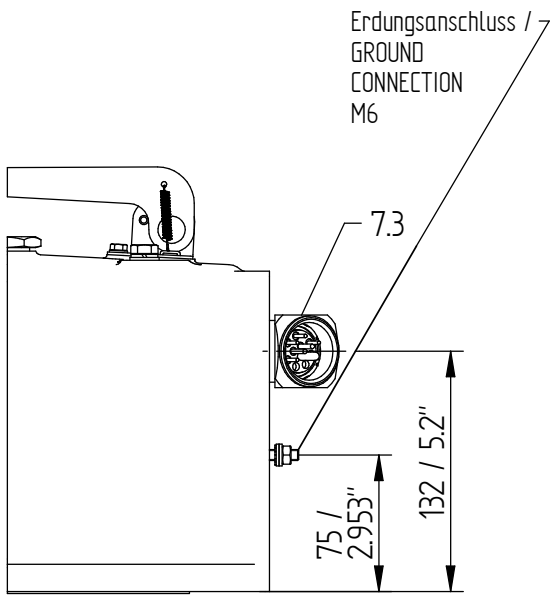
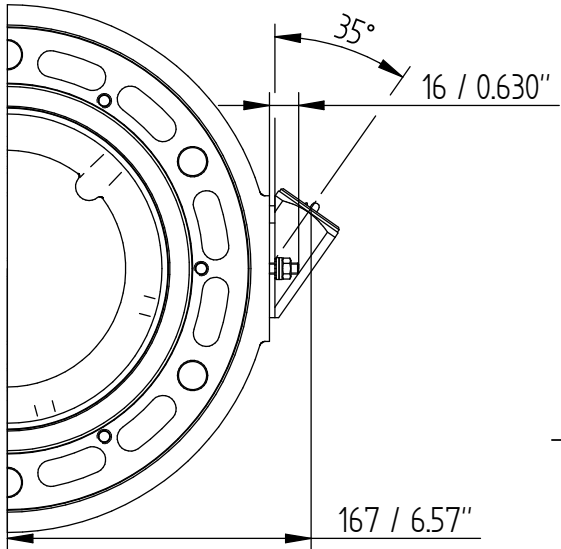

© MASCHINENFABRIK REINHAUSEN GMBH 2020  
 THE REPRODUCTION, DISTRIBUTION AND UTILIZATION OF THIS DOCUMENT AS WELL AS THE COMMUNICATION OF ITS CONTENTS TO OTHERS WITHOUT EXPRESS AUTHORIZATION IS PROHIBITED. OFFENDERS WILL BE HELD LIABLE FOR THE PAYMENT OF DAMAGES. ALL RIGHTS RESERVED IN THE EVENT OF THE GRANT OF A PATENT, UTILITY MODEL OR DESIGN.

DATE	NAME	DOCUMENT NO.
02.08.2023	THIELEK	SED 7266974-000 03
02.08.2023	SCHAEFERB	CHANGE NO.
02.08.2023	KLEYN	1123935
		SCALE
		1:2

DIMENSION  
 IN mm  
 EXCEPT AS  
 NOTED



TRANSFORMER ACCESSORIES  
 PRESSURE RELIEF DEVICE MPREC  
 OD (OIL DIRECTED) COVER - 1/2" NPT - ADAPTER

SERIAL NUMBER

MATERIAL NUMBER  
 101591110M

SHEET  
 3 / 3

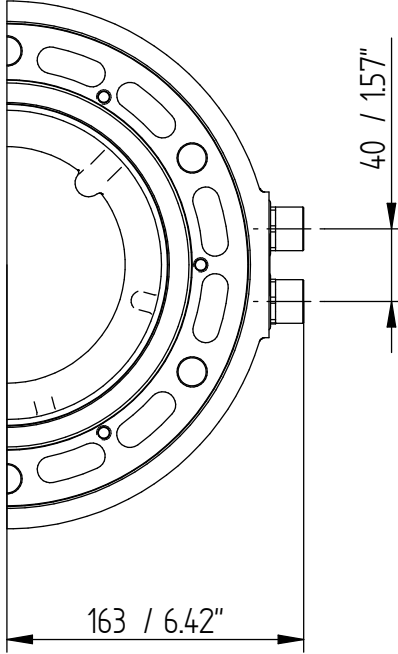
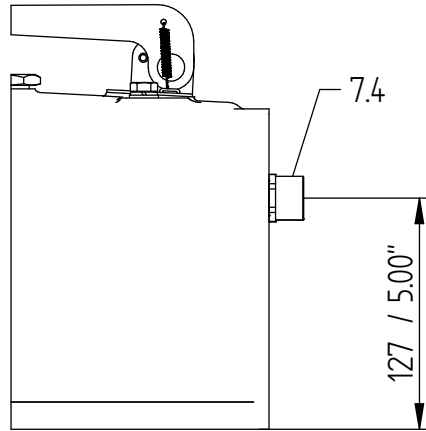

bez.	Datum	Name	Dokumentennummer
Exp.	14.07.2022	THIELEK	SED 8235729 000 00
Norm.	14.07.2022	STOPPEL	Änderungsnummer
		KLEYN	11165915
			12

Maßangaben  
in mm, soweit  
nicht anders  
angegeben



TRANSFORMER ACCESSORIES  
 MPREC Ableitrohr/DRAINAGE PIPE  
 Maßzeichnung/DIMENSION DRAWING

Serialnummer	-
Materialnummer	101716100M
Blatt	1 / 3

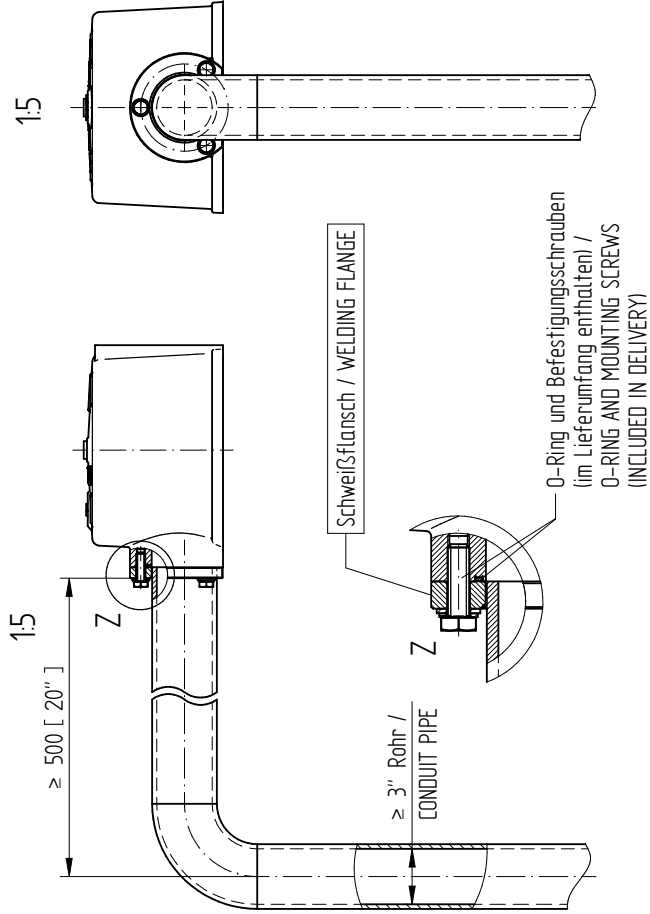

MASCHINENFABRIK REINHARDSEN GMBH COPYRIGHT RESERVED  
 THE REPRODUCTION, DISTRIBUTION AND UTILIZATION OF THIS DOCUMENT AS WELL AS THE COMMUNICATION OF ITS CONTENTS TO OTHERS WITHOUT EXPRESS AUTHORIZATION IS PROHIBITED. OFFENDERS WILL BE HELD LIABLE FOR THE PAYMENT OF DAMAGES. ALL RIGHTS RESERVED IN THE EVENT OF A PATENT, UTILITY MODEL OR DESIGN.

Bez.	14.07.2022	Name	Dokumentennummer
Exp.	14.07.2022	THELEK	SED 8235729 000 00
Norm.	14.07.2022	STOPPEL	Änderungsnummer
		KLEYN	11165915
			Maßstab
			1:2

Maßangaben  
 in mm, soweit  
 nicht anders  
 angegeben



Schweißflansch Bestell-Nr. / WELDING FLANGE ORDER NO.: 74045001  
 Werkstoff / MATERIAL: X5CrNi18-10 (1.4301, AISI 304)

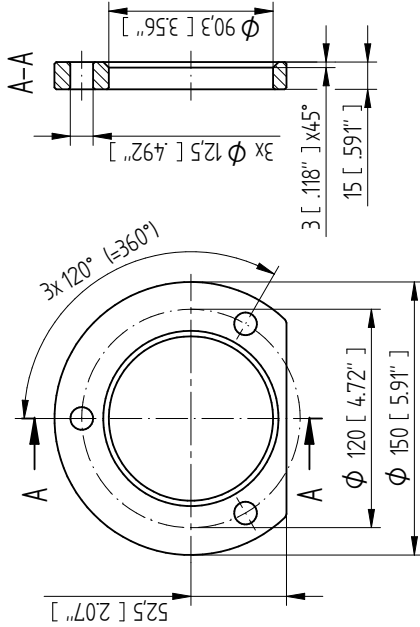

TRANSFORMER ACCESSORIES  
 MPREC Ableitrohr/DRAINAGE PIPE  
 Maßzeichnung/DIMENSION DRAWING

Serialnummer	-
Materialnummer	101716100M
Blatt	2 / 3

MASCHINENFABRIK REINHARDT GMBH COPYRIGHT RESERVED  
 THE REPRODUCTION, DISTRIBUTION AND UTILIZATION OF THIS DOCUMENT AS WELL AS THE COMMUNICATION OF ITS CONTENTS TO OTHERS WITHOUT EXPRESS AUTHORIZATION IS PROHIBITED. OFFENDERS WILL BE HELD LIABLE FOR THE PAYMENT OF DAMAGES. ALL RIGHTS RESERVED IN THE EVENT OF A PATENT, UTILITY MODEL OR DESIGN.

Bez.	14.07.2022	Name	Dokumentennummer
Exp.	14.07.2022	THELEK	SED 8235729 000 00
Norm.	14.07.2022	STOPPEL	Änderungsnummer
		KLEYN	11165915
			12

Maßangaben  
 in mm, soweit  
 nicht anders  
 angegeben



Gewindeflansch Bestell-Nr. / FLANGE INTERNAL THREAD ORDER NO. 73647901  
 Werkstoff / MATERIAL X5CrNi18-10 (1.4301, AISI 304)

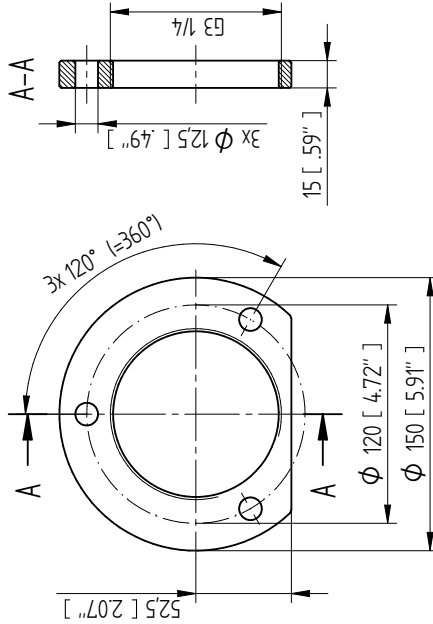

TRANSFORMER ACCESSORIES  
 MPREC Ableitrohr/DRAINAGE PIPE  
 Maßzeichnung/DIMENSION DRAWING

Serialnummer	
-	
Materialnummer	Blatt
101716100M	3 / 3

# Glossary

## **Ambient air temperature**

Permissible temperature of the air in the surroundings of the equipment in operation on which the device is installed.

## **Insulating fluid temperature**

Permissible temperature of the insulating fluid in the product or directly on the product.

## **Operating temperature**

Permissible temperature in the immediate surroundings of the device during operation taking ambient influences, for example due to the equipment and installation location, into consideration.

## **Storage temperature**

Permissible temperature for storing the device in an unmounted state or in a mounted state so long as the device is not in operation.





## **Maschinenfabrik Reinhausen GmbH**

Falkensteinstrasse 8

93059 Regensburg

Germany

+49 941 4090-0

info@reinhausen.com

**reinhausen.com**

**Please note:**

The data in our publications may differ from the data of the devices delivered. We reserve the right to make changes without notice.

5789879/05 EN - MESSKO<sup>®</sup> MPREC<sup>™</sup> Operating instructions -

F0358705 - 10/23

Maschinenfabrik Reinhausen GmbH 2023



THE POWER BEHIND POWER.